



**Kenya National Highways Authority**

**Quality Highways, Better Connections**

**REQUEST FOR PROPOSALS**

**FOR**

**MANAGEMENT, OPERATION AND MAINTENANCE OF  
WEBUYE WEIGHBRIDGE STATION AND THE 2073 KM  
ADJACENT ROAD NETWORK.**

**TENDER NO. KeNHA/2824/2024**

**OCTOBER 2024**

**DIRECTOR MAINTENANCE  
KENYA NATIONAL HIGHWAYS  
AUTHORITY  
P.O. Box 49712-00100  
NAIROBI**

**DIRECTOR GENERAL  
KENYA NATIONAL HIGHWAYS  
AUTHORITY  
P.O. BOX 49712 - 00100  
NAIROBI**

## Table of Contents

<b>SECTION 1 - REQUEST FOR PROPOSALS (RFP)</b> .....	<b>3</b>
<b>SECTION 2: INSTRUCTIONS TO TENDERERS AND DATA SHEET</b> .....	<b>5</b>
<b>SECTION 2(A): INSTRUCTIONS TO TENDERERS (ITT)</b> .....	<b>5</b>
A. GENERAL PROVISIONS .....	5
B. PREPARATION OF PROPOSALS .....	11
C. SUBMISSION, OPENING AND EVALUATION.....	17
D. NEGOTIATIONS AND AWARD .....	26
<b>SECTION 2 (B). DATA SHEET</b> .....	<b>29</b>
<b>SECTION 3- EVALUATION AND QUALIFICATION CRITERIA</b> .....	<b>38</b>
<b>SECTION 4. TECHNICAL PROPOSAL – STANDARD FORMS</b> .....	<b>44</b>
<b>FORM TECH-1: FORM OF TENDER - TECHNICAL PROPOSAL SUBMISSION FORM</b> .....	<b>44</b>
<b>1 FORM ELI-1.1- TENDERER INFORMATION</b> .....	<b>46</b>
<b>2 FORM ELI- 1.2- TENDERER JV INFORMATION</b> .....	<b>47</b>
<b>FORM TECH-2: CONFIDENTIAL BUSINESS QUESTIONNAIRE</b> .....	<b>48</b>
<b>FORM TECH-3: CONFLICT OF INTEREST DISCLOSURE</b> .....	<b>50</b>
<b>FORM TECH-4: CERTIFICATE OF INDEPENDENT PROPOSAL DETERMINATION</b> .....	<b>51</b>
<b>FORM TECH-6: CONTRACTOR'S ORGANIZATION AND EXPERIENCE</b> .....	<b>60</b>
<b>FORM TECH-7: COMMENTS AND SUGGESTIONS</b> .....	<b>61</b>
<b>FORM TECH-8: DESCRIPTION OF APPROACH, METHODOLOGY AND WORK PLAN</b> .....	<b>62</b>
<b>FORM TECH-9: WORK SCHEDULE</b> .....	<b>63</b>
<b>FORM TECH-10: FINANCIAL SITUATION AND PERFORMANCE</b> .....	<b>64</b>
<b>FORM TECH – 11: AVERAGE ANNUAL TURNOVER</b> .....	<b>68</b>
<b>FORM TECH 12: CURRENT CONTRACT COMMITMENTS / WORKS IN PROGRESS</b> .....	<b>69</b>
<b>FORM EQU: CONTRACTOR'S EQUIPMENT</b> .....	<b>71</b>
<b>FORM PER -1: KEY PERSONNEL SCHEDULE</b> .....	<b>72</b>
<b>FORM PER -2</b> .....	<b>73</b>
<b>FORM PER 3: CURRICULUM VITAE (CV)</b> .....	<b>75</b>
<b>FORMTECH-13: MANDATORY SUPPORT DOCUMENTS</b> .....	<b>77</b>
<b>FORM TECH – 14: FORM OF TENDER SECURITY - FORM OF DEMAND GUARANTEE</b> .....	<b>78</b>
<b>FORM TECH - 15: TENDER-SECURING DECLARATION FORM</b> .....	<b>79</b>
<b>FORM TECH – 16: FORM OF WRITTEN POWER OF ATTORNEY</b> .....	<b>80</b>
<b>FORM TECH – 17: HISTORICAL CONTRACT NON-PERFORMANCE, PENDING LITIGATION AND LITIGATION HISTORY</b> .....	<b>81</b>
<b>FORM TECH – 18: DECLARATION FORM – FAIR EMPLOYMENT LAW AND PRACTICES</b> .....	<b>82</b>
<b>PERFORMANCE BANK GUARANTEE</b> .....	<b>84</b>
<b>SECTION 4. FINANCIAL PROPOSAL - STANDARD FORMS</b> .....	<b>93</b>
<b>FORM OF TENDER</b> .....	<b>96</b>
<b>FORM FIN-1: FINANCIAL PROPOSAL SUBMISSION FORM</b> .....	<b>98</b>
<b>FORM FIN-2: SUMMARY OF COSTS</b> .....	<b>99</b>
<b>FORM FIN-3: BREAKDOWN OF PRICE PER ACTIVITY</b> .....	<b>99</b>
<b>FORM FIN-4: BREAKDOWN OF REMUNERATION PER ACTIVITY</b> .....	<b>100</b>
<b>SECTION 5. -TERMS OF REFERENCE</b> .....	<b>127</b>

[October 2024]

<b>5.0 BACKGROUND INFORMATION</b> .....	<b>127</b>
<b>5.1 GENERAL</b> .....	<b>127</b>
<b>5.2 SELECTION CRITERIA</b> .....	<b>127</b>
<b>5.3 PROJECT DESCRIPTION</b> .....	<b>127</b>
<b>5.4 CONTRACT OBJECTIVES</b> .....	<b>128</b>
<b>5.5 ASSUMPTIONS &amp; RISKS</b> .....	<b>134</b>
<b>5.6 SCOPE OF THE WORK</b> .....	<b>134</b>
<b>5.7 DETAILED DESCRIPTION OF THE SERVICES</b> .....	<b>137</b>
<b>5.8 PROJECT MANAGEMENT, CONTRACTUAL FRAMEWORK AND</b> .....	<b>140</b>
<b>5.9 LOGISTICS AND TIMING</b> .....	<b>140</b>
<b>5.10 REQUIREMENTS</b> .....	<b>142</b>
<b>5.11 WORK SCHEDULE</b> .....	<b>149</b>
<b>5.12 PROVISION OF TRANSPORT</b> .....	<b>149</b>
<b>5.13 FACILITIES TO BE PROVIDED BY THE CONTRACTOR</b> .....	<b>150</b>
<b>5.14 FACILITIES TO BE PROVIDED BY THE EMPLOYER</b> .....	<b>150</b>
<b>5.15 REPORTS</b> .....	<b>151</b>
<b>5.16 MONITORING AND EVALUATION</b> .....	<b>152</b>
<b><u>SECTION 6: GENERAL CONDITIONS OF CONTRACT (FIDIC CONDITIONS)</u></b> .....	<b><u>156</u></b>
<b><u>SECTION 7: SPECIAL CONDITIONS OF CONTRACT</u></b> .....	<b><u>164</u></b>
<b>SECTION XI - CONTRACT FORMS</b> .....	<b>166</b>
<b>FORM NO. 1 - NOTIFICATION OF INTENTION TO AWARD</b> .....	<b>167</b>
<b>FORM NO. 3 - NOTIFICATION OF AWARD</b> .....	<b>171</b>
<b>FORM NO. 4 – CONTRACT AGREEMENT</b> .....	<b>172</b>
<b>FORM NO. 5 - PERFORMANCE SECURITY</b> .....	<b>173</b>
<b>FORM NO. 6 - ADVANCE PAYMENT SECURITY</b> .....	<b>174</b>
<b>FORM NO. 7 - RETENTION MONEY SECURITY</b> .....	<b>176</b>

[October 2024]

## **SECTION 1 - REQUEST FOR PROPOSALS (RFP)**

**PROCURING ENTITY:** KENYA NATIONAL HIGHWAYS AUTHORITY

**CONTRACT NAME AND DESCRIPTION:** TENDER FOR THE MANAGEMENT, OPERATION AND MAINTENANCE OF WEBUYE WEIGHBRIDGE STATION AND THE 2073 KM ADJACENT ROAD NETWORK

Kenya National Highways Authority invites sealed tenders for the **Management, Operation and Maintenance of Webuye Weighbridge Station and the 2073 Km Adjacent Road Network** through a Twenty-Eight (28) months Output Based Performance Contract.

1. Tendering will be conducted under open competitive method (National) using a standardized tender document. Tendering is open to all qualified and interested Tenderers.
2. Qualified and interested tenderers may obtain further information and inspect the Tender Documents during office hours **[0800 to 1700 hours Mondays to Fridays]**, *excluding* Public Holidays at the address below (item 4).
3. A complete set of tender documents may be obtained by interested tenderers from the Kenya National Highways Authority website: **www.kenha.co.ke** or Public Procurement Information Portal (PIIP) website: **www.tenders.go.ke** free of charge OR from the offices indicated in the table above during normal working hours upon payment of a non - refundable fee of **Kshs. 1,000.00 (One Thousand Shillings Only)** in form of banker's cheque only payable to Kenya National Highways Authority. below:  
Bidders are encouraged to download tender documents to minimize physical visits to **KeNHA Headquarter Office**.
4. Completed tender documents are to be enclosed in plain sealed envelope clearly marked with tender name, reference number and submitted to: -

**Deputy Director – Supply Chain Management,  
Kenya National Highways Authority,  
P. O. Box 49712-00100, Nairobi  
Barabara Plaza, Jomo Kenyatta International Airport,  
Mazao Road, Off Airport North Road, Block C 2<sup>nd</sup> Floor**

and deposited in the Tender Box located at **KeNHA's Supply Chain Management Office, 2nd Floor, Block C, North Wing, Barbara Plaza**, so as to be received on or before, **Thursday, 28<sup>th</sup> November, 2024 at 11.00AM**.

**Please note that bulky Tender Documents which do not fit in the tender box shall be delivered to the Supply Chain Management Office at Barabara Plaza, Block C 2nd Floor.**

5. All Tenders must be accompanied by an original tender security (**Value KSh. 750,000.00**) in the form of Unconditional Bank Guarantee from a reputable bank in Kenya.

[October 2024]

6. The Tenderer shall chronologically serialize all pages of the tender documents submitted.
7. Electronic Tenders will not be permitted. Late tenders will be rejected.
8. All interested bidders are required to continually check the Kenya National Highways Authority website: **www.kenha.co.ke** or Public Procurement Information Portal (PIIP) website: **www.tenders.go.ke** for any tender addenda or clarifications that may arise before the submission date.
9. Tenders will be opened immediately thereafter in the presence of Tenderers/Representatives who wish to attend at the **2nd Floor, Block C Boardroom, Barbara Plaza, Mazao Road off Airport South Road** as indicated above.

**Deputy Director, Supply Chain Management**  
**For: DIRECTOR GENERAL**

[October 2024]

## **SECTION 2: INSTRUCTIONS TO TENDERERS AND DATA SHEET**

### **SECTION 2(A): INSTRUCTIONS TO TENDERERS (ITT)**

#### **A. GENERAL PROVISIONS**

##### **1. Meanings/Definitions**

- a) “Affiliate(s)” means an individual or an entity that directly or indirectly controls, is controlled by, or is under common control with the Tenderer.
- b) “Applicable Law” means the laws and any other instruments having the force of law in Kenya.
- c) “Procuring Entity” means the entity that is carrying out the Contractor selection process and signs the Contract for the Services with the selected Tenderer.
- d) “Contractor” means a legally-established business or an entity that may provide or provides the Services to the Procuring Entity under the Contract.
- e) “Contract” means a legally binding written agreement signed between the Procuring Entity and the Contractor and includes all the attached documents listed in its Clause 1 (the General Conditions of Contract (GCC), the Special Conditions of Contract (SCC), and the Appendices.
- f) “Data Sheet” means an integral part of the Instructions to Tenderers (ITT) Section 2 that is used to reflect specific assignment conditions to supplement, but not to over-write, the provisions of the ITT.
- g) “Day” means a calendar day unless otherwise specified as "Business Day". A Business Day is any day that is an official working day in Kenya and excludes official public holidays.
- h) “Experts” means, collectively, Key Staff, Non-Key Staff, or any other personnel of the Contractor, Sub-Contractor or Joint Venture member(s).
- i) “Government” means the Government of the Republic of Kenya.
- j) “In writing” means communicated in written form such as by mail, e-mail, fax, including, if specified in the Data Sheet, distributed or received through the electronic-procurement system used by the Procuring Entity with proof of receipt.

[October 2024]

- k) “Joint Venture (JV)” means an association with or without a legal personality distinct from that of its members, of more than one Contractor where one member has the authority to conduct all business for and on behalf of any and all the members of the JV, and where the members of the JV are jointly and severally liable to the Procuring Entity for the performance of the Contract.
- l) “Key Expert(s)” means an individual professional whose skills, qualifications, knowledge and experience are critical to the performance of the Services under the Contract and whose CV is considered in the technical evaluation of the Tenderer's proposal.
- m) “ITT” (this Section 2 of the RFP) means the Instructions to Tenderers that provides the Tenderers with all information needed to prepare their Proposals.
- n) “Letter of RFP” means the letter of invitation being sent by the Procuring Entity to the Tenderers.
- o) “Non-Key Expert(s)” means an individual professional provided by the Tenderer or its Sub-Tenderer and who is assigned to perform the Services or any part thereof under the Contract and whose CVs are not evaluated individually.
- p) “Proposal” means the Technical Proposal and the Financial Proposal of the Tenderer.
- q) “Public Procurement Regulatory Authority (PPRA)” means the statutory authority of the Government of Kenya that is mandated with the role of regulating and monitoring compliance with the public procurement law and regulations.
- r) “RFP” means the Request for Proposals to be prepared by the Procuring Entity for the selection of Tenderers.
- s) “Services” means the work to be performed by the Tenderer pursuant to the Contract.
- t) “Sub-Contractor” means an entity to whom the Contractor intends to sub-contract for any part of the Services while the Contractor remains responsible to the Procuring Entity during the whole performance of the Contract. The Contractor shall not subcontract more than 70% of the works comprising the assignment in terms of the value of the contract sum.

[October 2024]

*No sub-contractor in any aspect of the work shall be engaged by the Main Contractor without the approval of the Engineer.*

- u) “Terms of Reference (TOR)” means the Terms of Reference that explains the objectives, scope of work, activities, and tasks to be performed, respective responsibilities of the Procuring Entity and the Tenderer, and expected results and deliverables of the assignment.

## **2. Introduction**

- 2.1 The Procuring Entity named in the Data Sheet intends to select a Tenderer from those listed in the Request for Proposals (RFP), in accordance with the method of selection specified in the Data Sheet.
- 2.2 The Tenderers are invited to submit a Technical Proposal and a Financial Proposal, for the services required for the assignment named in the Data Sheet. The Proposal will be the basis for negotiating and ultimately signing the Contract with the selected Tenderer.
- 2.3 The Tenderers should familiarize themselves with the local conditions and take them into account in preparing their Proposals, including attending a pre-proposal conference if one is specified in the Data Sheet. Attending any such pre-proposal conference is mandatory and is at the Tenderers' expense.
- 2.4 The Procuring Entity will timely provide, at no cost to the Tenderers, the inputs, relevant project data, and reports required for the preparation of the Tenderer's Proposal as specified in the Data Sheet.

## **3. Conflict of Interest**

- 3.1 The Tenderer is required to provide professional, objective, and impartial advice, always holding the Procuring Entity's interest's paramount, strictly avoiding conflicts with other assignments or its own corporate interests and acting without any consideration for future work.
- 3.2 The Tenderer has an obligation to disclose to the Procuring Entity any situation of actual or potential conflict that impacts its capacity to serve the best interest of the Procuring Entity. Failure to disclose such situations may lead to the disqualification of the Tenderer or the termination of its Contract.



[October 2024]

3.3 Without limitation on the generality of the foregoing, and unless stated otherwise in the Data Sheet, the Tenderers shall not be hired under the circumstances set forth below:

*i) Conflicting Activities*

Conflict between consulting activities and procurement of goods, works or non-consulting services: a firm that has been engaged by the Procuring Entity to provide goods, works, or non-consulting services for a project, or any of its Affiliates, shall be disqualified from providing consulting services resulting from or directly related to those goods, works, or non-consulting services. Conversely, a firm hired to provide consulting services for the preparation or implementation of a project, or any of its Affiliates, shall be disqualified from subsequently providing goods or works or non-consulting services resulting from or directly related to the consulting services for such preparation or implementation.

*ii) Conflicting Assignments*

Conflict among consulting assignments: A Tenderer (including its Experts and Sub-Tenderers) or any of its Affiliates shall not be hired for any assignment that, by its nature, may conflict with another assignment of the Tenderer for the same or for another Procuring Entity.

*(iii) Conflicting Relationships*

Relationship with the Procuring Entity's staff: a Tenderer (including its Experts and Sub-Tenderers) that has a close business or personal relationship with senior management or professional staff of the Procuring Entity who has the ability to influence the bidding process and:

- (i) are directly or indirectly involved in the preparation of the Terms of Reference for the assignment,
- (ii) the selection process for the Contract, or
- (iii) the supervision of the Contract, may not be awarded a Contract, unless the conflict stemming from such relationship has been resolved in a manner that determines there is no conflict to affect this selection process.

*iii) Others*

Any other types of conflicting relationships

[October 2024]

#### **4. Unfair Competitive Advantage**

Fairness and transparency in the selection process require that the Tenderers or their Affiliates competing for a specific assignment do not derive a competitive advantage from having provided the services related to the assignment in question.

#### **5. Corrupt and Fraudulent Practices**

- 5.1 Tenderer firms or any of its members shall not be involved in corrupt, coercive, obstructive, collusive or fraudulent practice. Tenderer firms or any of its members that are proven to have been involved in any of these practices shall be automatically disqualified and would not be awarded a contract.

#### **6. Collusive practices**

- 6.1 The Procuring Entity requires compliance with the provisions of the Competition Act 2010, regarding collusive practices in contracting. Any Tenderer found to have engaged in collusive conduct shall be disqualified and criminal and/or civil sanctions may be imposed. To this effect, Tenderers shall be required to complete and sign the “Certificate of Independent Proposal Determination” annexed to the Proposal Form.
- 6.2 In further pursuance of this policy, Tenderers shall permit and shall cause their agents (where declared or not), subcontractors, service providers, suppliers, and their personnel, to permit the Government and its agencies to inspect all accounts, records and other documents relating to any short-listing process, Proposal submission, and contract performance (in the case of award), and to have them audited by auditors, investigators or compliance officers.

#### **7. Eligibility**

- 7.1 In selection of Tenderers, short-listing shall be composed of firms or individuals who belong to the same line of professional business and who are almost of the same capability.
- 7.2 Unless otherwise specified in the Data Sheet, the Procuring Entity permits Tenderers including proposed experts, joint ventures and individual members from all countries and categories to offer management services. The maximum number of members so far in a JV shall be specified in the TDS.

[October 2024]

- 7.3 The Competition Act of Kenya requires that firms wishing to tender as Joint Venture undertakings which may prevent, distort or lessen competition in provision of services are prohibited unless they are exempt in accordance with the provisions of Section 25 of the Competition Act, 2010. **JVs will be required to seek for exemption from the Competition Authority.** Exemption shall not be a condition for submission of proposals, but it shall be a condition of contract award and signature. A JV tenderer shall be given opportunity to seek such exemption as a condition of award and signature of contract. Application for exemption from the Competition Authority of Kenya may be accessed from the website [www.cak.go.ke](http://www.cak.go.ke)
- 7.4 Public Officers of the Procuring Entity, their Spouses, Child, Parent, Brothers or Sister. Child, Parent, Brother or Sister of a Spouse, their business associates or agents and firms/organizations in which they have a substantial or controlling interest shall not be eligible to tender or be awarded a contract. Public Officers are also not allowed to participate in any procurement proceedings.
- 7.5 It is the Tenderer's responsibility to ensure that it's Experts, joint venture members, Sub-Tenderers, agents (declared or not), sub-contractors, service providers, suppliers and/or their employees meet the eligibility requirements.
- 7.6 As an exception to the foregoing ITT 7.1 and 7.2 above:
- a) Sanctions-  
  
A firm or an individual that has been debarred from participating in public procurement shall be ineligible to be awarded a contract, or to benefit from the contract, financially or otherwise, during the debarment period. The list of debarred firms and individuals is available from the website of PPRA [www.ppra.go.ke](http://www.ppra.go.ke).
  - b) Prohibitions-Firms and individuals of a country or goods in a country maybe ineligible if:
    - i) As a matter of law or official regulations, Kenya prohibits commercial relations with that country; or
    - ii) By an act of compliance with a decision of the United Nations Security Council taken under Chapter VII of the Charter of the United Nations, Kenya prohibits any import of goods or services from that country or any payments to any country, person, or entity in that country.

[October 2024]

- c) Restrictions for Government-owned Enterprises or institutions in Kenya shall be eligible only if they can establish that they
  - i) Are legally and financially autonomous,
  - ii) Operate under commercial law, and
  - iii) That they are not dependent agencies of the Procuring Entity.
- d) Restrictions for public employees - Government officials and civil servants and employees of public institutions shall not be hired for consulting contracts.

7.7 Margin of Preference and Reservations. Margin of preference shall be allowed in the selection of Tenderers. Reservations may however be allowed to a specific group of businesses (these groups are Small and Medium Enterprises, Women Enterprises, Youth Enterprises and Enterprises of persons living with disability, as the case may be), and who are appropriately registered as such by the authority to be specified in the Data Sheets. A procuring entity shall ensure that the invitation to submit proposals specifically includes only businesses or firms belonging to one group.

## **B. PREPARATION OF PROPOSALS**

### **8 General Considerations**

8.1 In preparing the Proposal, the Tenderer is expected to examine the RFP in detail. Material deficiencies in providing the information requested in the RFP may result in rejection of the Proposal.

### **9 Cost of Preparation of Proposal**

9.1 The Tenderer shall bear all costs associated with the preparation and submission of its Proposal, and the Procuring Entity shall not be responsible or liable for those costs, regardless of the conduct or outcome of the selection process. The Procuring Entity is not bound to accept any proposal and reserves the right to annul the selection process at any time prior to Contract award, without there by incurring any liability to the Tenderer.

### **10 Language**

10.1 The Proposal, as well as all correspondence and documents relating to the Proposal exchanged between the Tenderer and the Procuring Entity shall be written in the English language.

[October 2024]

## **11 Documents Comprising the Proposal**

- 11.1 The Proposal shall comprise the documents and forms listed in the Data Sheet.
- 11.2 The Tenderer shall declare in the Financial Proposal Submission Form, that in competing for and executing a contract, it shall undertake to observe the laws of Kenya against fraud and corruption including bribery, as well as against anti-competitive practices including bid rigging.
- 11.3 The Tenderer shall furnish information on commissions, gratuities and fees, if any, paid or to be paid to agents or any other party relating to this Proposal and, if awarded, Contract execution, as requested in the Financial Proposal Submission Form.

## **12 Only One Proposal**

- 12.1 The Tenderer (including the individual members of any Joint Venture) shall submit only one Proposal, either in its own name or as part of a Joint Venture in another Proposal. If a Tenderer, including any Joint Venture member, submits or participates in more than one proposal, all such proposals shall be disqualified and rejected. This does not, however, preclude Sub-Tenderer, or the Tenderer's staff from participating as Key and Non-Key staff in more than one Proposal when circumstances justify and if stated in the Data Sheet.
- 12.2 Members of a joint venture may not also make an individual Proposal, be a subcontractor in a separate proposal or be part of another joint venture for the purposes of the same Contract.
- 12.3 Should a Joint Venture subsequently win the Contract, it shall consider whether an application for exemption from the Competition Authority of Kenya is merited pursuant to Section 25 of the Competition Act 2010.

## **13 Proposal Validity**

### **a. Proposal Validity Period**

- 13.1 The Data Sheet indicates the period during which the Tenderer's Proposal must remain valid after the Proposal submission deadline.
- 13.2 During this period, the Tenderer shall maintain its original Proposal without any change, including the availability of the Key staff, the proposed rates and the total price.

[October 2024]

13.3 If it is established that any Key staff nominated in the Tenderer's Proposal was not be available at the time of Proposal submission or was included in the Proposal without his/her confirmation, such Proposal shall be disqualified and rejected for further evaluation and may be subject to sanctions in accordance with IT C5.

**b. Extension of Validity Period**

13.4 The Procuring Entity will make its best effort to complete the negotiations within the proposal's validity period. However, should the need arise, the Procuring Entity may request, in writing, all Tenderers who submitted Proposals prior to the submission deadline to extend the Proposals' validity.

13.5 If the Tenderer agrees to extend the validity of its Proposal, it shall be done without any change in the original Proposal and with the confirmation of the availability of the Key staff, except as provided in ITT13.7.

13.6 The Tenderer has the right to refuse to extend the validity of its Proposal in which case such Proposal will not be further evaluated.

**c. Substitution of Key staff at Validity Extension**

13.7 If any of the Key staff become unavailable for the extended validity period, the Tenderer shall provide a written adequate justification and evidence satisfactory to the Procuring Entity together with the substitution request. In such case, a replacement Key staff shall have equal or better qualifications and experience than those of the originally proposed Key staff. The technical evaluations score, however, will remain to be based on the evaluation of the CV of the original Key staff.

13.8 If the Tenderer fails to provide a substitute Key staff with equal or better qualifications, or if the provided reasons for the replacement or justification are unacceptable to the Procuring Entity, such Proposal will be rejected.

**d. Sub-Contracting**

13.9 The Contractor shall not subcontract the whole or part of the Services without reasonable justification and written approval of the Procuring Entity.

[October 2024]

## **14 Clarification and Amendment of RFP**

14.1 The Tenderer may request a clarification of any part of the RFP during the period indicated in the Data Sheet before the Proposals' submission deadline. Any request for clarification must be sent in writing, or by standard electronic means, to the Procuring Entity's address indicated in the Data Sheet. The Procuring Entity will respond in writing, or by standard electronic means, and will send written copies of the response (including an explanation of the query but without identifying its source) to all Tenderers. Should the Procuring Entity deem it necessary to amend the RFP as a result of a clarification, it shall do so following the procedure described below:

14.2 At any time before the proposal submission deadline, the Procuring Entity may amend the RFP by issuing an amendment in writing or by standard electronic means. The amendment shall be sent to all invited Tenderers and will be binding on them. The Tenderers shall acknowledge receipt of all amendments in writing.

14.3 If the amendment is substantial, the Procuring Entity may extend the proposal submission deadline to give the Tenderers reasonable time to take an amendment in to account in their Proposals.

14.4 The Tenderer may submit a modified Proposal or a modification to any part of it at any time prior to the proposal submission deadline. No modifications to the Technical or Financial Proposal shall be accepted after the deadline.

## **15 Preparation of Proposals–Specific Considerations**

15.1 While preparing the Proposal, the Tenderer must give particular attention to the following:

15.2 If a Tenderer considers that it may enhance its expertise for the assignment by associating with other Tenderers in the form of a Joint Venture or as Sub-Tenderers, it may do so long as only one Proposal is submitted, in accordance with ITT 11 above. A Tenderer cannot associate with shortlisted Tenderer(s). When associating with non-shortlisted/non-invited firms in the form of a joint venture or a sub-consultancy, the shortlisted/invited Tenderer shall be a lead member. If shortlisted/invited Tenderer associates with each other, any of them can be a lead member.

[October 2024]

15.3 The Procuring Entity may indicate in the Data Sheet the estimated amount or Key staff' time input (expressed in person-month), or the Procuring Entity's estimated total cost of the assignment, but not both. This estimate is indicative and the Proposal shall be based on the Tenderer's own estimates for the same. This clause shall not apply when using Fixed Budget selection method.

15.4 Site Staff shall not appear in more than one proposal for same Bidder unless so allowed in the Data Sheet. Invited firms must ensure their Site staff do not appear in more than one proposal, otherwise their proposals with Site staff appearing in more than one proposal will be rejected.

## **16 Site Visit and Data Room**

16.1 The Tenderer, at the Tenderer's own responsibility and risk, is encouraged to visit and examine the Site of the Required Services and its surroundings and obtain all information that may be necessary for preparing the Tender and entering into a contract for the Services. The costs of visiting the Site shall be at the Tenderer's own expense.

16.2 The Procuring Entity has established a data room (herein after called the Data Room) with a selection of relevant data to be accessible to Tenderers or their representatives. The address of the Data Room, and other information considered relevant by the Procuring Entity (such as an inventory of materials, or dates, rules and procedures for access, and dates of availability) areas specified in the TDS.

## **17 Pre-Tender Meeting and a pre-arranged pretender visit of the site of the works**

17.1 A pre-tender conference will be held, at a date and venue specified in the TDS. Details of the pre-arranged pretender visit of the site of the works will be as specified in the TDS. The Tenderer's designated representative is invited to attend a pre-arranged pretender visit of the site of the works. The purpose of the meeting will be to clarify issues and to answer questions on any matter that may be raised at that stage.

17.2 The Tenderer is requested to submit any questions in writing, to reach the Procuring Entity not later than the period specified in the TDS before the meeting.

17.3 Minutes of the pre-Tender meeting and the pre-arranged pretender visit of the site of the works, including the text of the questions asked by Tenderers and the responses given, together with any responses prepared after the meeting, will be transmitted promptly to all Tenderers who



[October 2024]

have acquired the Tender Documents. Minutes shall not identify the source of the questions asked.

17.4 The Procuring Entity shall also promptly publish anonymized (no names) Minutes of the pre-Tender meeting and the pre-arranged pretender visit of the site of the works at the webpage identified in the TDS. Any modification to the Tender Documents that may become necessary as a result of the pre-Tender meeting shall be made by the Procuring Entity exclusively through the issue of an Addendum pursuant to ITT 14 and not through the minutes of the pre-Tender meeting. **Attendance of the Pre-Tender Conference meeting will be mandatory and Non-attendance will be a cause for disqualification of a Tenderer.**

## **18 Technical Proposal Format and Content**

18.1 The Technical Proposal shall be prepared using the Standard Forms provided in Section 3 of the RFP and shall comprise the documents listed in the Data Sheet under ITT 11.1. The Technical Proposal shall not include any financial information. **A Technical Proposal containing material financial information shall be declared non-responsive.**

**18.2** Tenderer shall not propose alternative Key Staff. Only one CV shall be submitted for each Key Expert position. **Failure to comply with this requirement will make the Proposal non-responsive.**

## **19 Financial Proposal**

19.1 The Financial Proposal shall be prepared using the Standard Forms provided in Section 4 of the RFP. It shall list all costs associated with the assignment, including:

- (a) Performance of;
  - (i) Traffic counts,
  - (ii) Weighing vehicles evidenced by issuance of weighbridge ticket (where static weighing is done),
  - (iii) Impounding overloaded vehicles (costs in this include charging, offloading or redistribution of overload and issuance of compliance certificate) and;
- (b) Direct expenses such as
  - (i) Subsistence (per diem, housing),
  - (ii) Staff wages and emoluments.
  - (iii) transportation (international and local, for mobilization and demobilization).

[October 2024]

- (iv) services and equipment (vehicles, office equipment, furniture, and supplies), insurance, printing of documents, surveys, and training, if it is a major component of the assignment.

As appropriate these costs should be broken down by activity.

All this computation goes towards break-down of appropriate rates. Payment of the service will only be reimbursed according to the bills of quantities in this tender. There shall be no separate payments for any of the above expenses, except for the purpose of bids analysis and any future variation should it become necessary.

Irrespective of the Tenderer selection method, any Tenderer that does not submit itemized and priced financial proposal, or merely refers the Procuring Entity to other legal instruments for the applicable minimum remuneration fees shall be considered non-responsive.

**a. Price Adjustment**

- 19.2 For assignments with a duration exceeding 18 months, a price adjustment provision for foreign and/or local inflation for remuneration rates apply if so, stated in the Data Sheet.

**b. Taxes**

- 19.3 The Tenderer and its Sub-Tenderers and Experts are responsible for meeting all tax liabilities arising out of the Contract unless stated otherwise in the Data Sheet. Information on taxes in Kenya is provided in the Data Sheet.

**c. Currency of Proposal**

- 19.4 The Tenderer may express the price for its Services in the currency or currencies as stated in the Data Sheet. If indicated in the Data Sheet, the portion of the price representing local cost shall be stated in Kenya Shillings.

**d. Currency of Payment**

- 19.5 Payment under the Contract shall be made in the currency or currencies in which the payment is requested in the Proposal.

**C. SUBMISSION, OPENING AND EVALUATION**

**20 Submission, Sealing, and Marking of Proposals**

- 20.1 The Tenderer shall submit a signed and complete Proposal comprising the documents and forms in accordance with ITT 11 (Documents Comprising Proposal). Tenderers shall mark as

[October 2024]

“CONFIDENTIAL” information in their Proposals which is confidential to their business. This may include proprietary information, trade secrets or commercial or financially sensitive information. The submission can be done by mail or by hand. If specified in the Data Sheet, the Tenderer has the option of submitting its Proposals electronically.

- 20.2 An authorized representative of the Tenderer shall sign the original submission letters in the required format for both the Technical Proposal and the Financial Proposals and **shall initial all pages of both**. The authorization shall be in the form of a written power of attorney attached to the Technical Proposal. The bid shall be typed or written in indelible ink and shall be signed by the authorized representative. The person or persons signing the Proposal **shall initial all pages of both** Technical and Financial Proposal: **Any alterations made in the tender document must be countersigned. Non-initialization and countersigning shall constitute non-responsiveness.**
- 20.3 A Proposal submitted by a Joint Venture shall be signed by all members so as to be legally binding on all members, or by an authorized representative who has a written power of attorney signed by each member's authorized representative.
- 20.4 Any modifications, revisions, interlineations, erasures, or overwriting shall be valid only if they are signed or initialed by the person signing the Proposal.
- 20.5 The signed Proposal shall be marked “ORIGINAL”, and its copies marked “COPY” as appropriate. The number of copies is indicated in the Data Sheet. All copies shall be made from the signed original. If there are discrepancies between the original and the copies, the original shall prevail.

## **21 Sealing and Marking of Proposals**

- 21.1 The firm shall deliver the Proposals in a single sealed envelope, or in a single sealed package, or in a single sealed container bearing the name and Reference number of the assignment, addressed to the Procuring Entity and a warning “DO NOT OPEN BEFORE (The time and date for proposal opening date)”. Within the single envelope, package or container, the Firm shall place the following separate, sealed envelopes:
- 21.2 In the single sealed envelope, or in a single sealed package, or in a single sealed container the following documents shall be closed and shall be addressed as follows:

[October 2024]

- i) in an envelope or package or container marked “ORIGINAL”, all documents comprising the Technical Proposal, as described in ITT 11;
- ii) in an envelope or package or container marked “COPIES”, all required copies of the Technical Proposal;
- iii) in an envelope or package or container marked “ORIGINAL”, all required copies of the Financial Proposal; and

21.3 The inner envelopes or packages or containers shall:

- i) Bear the name and address of the Procuring Entity.
- ii) Bear the name and address of the Firm; and
- iii) Bear the name and Reference number of the Assignment.

21.4 If an envelope or package or container is not sealed and marked as required, the Procuring Entity will assume no responsibility for the misplacement or premature opening of the proposal. Proposals that are misplaced or opened prematurely will not be accepted.

21.5 The Proposal or its modifications must be sent to the address indicated in the Data Sheet and received by the Procuring Entity no later than the deadline indicated in the Data Sheet, or any extension to this deadline. Any Proposal or its modification received by the Procuring Entity after the deadline shall be declared late and rejected, and promptly returned unopened.

## **22 Confidentiality/Canvassing**

22.1 From the time the Proposals are opened to the time the Contract is awarded, the Tenderer should not contact the Procuring Entity on any matter related to its Technical and/or Financial Proposal. Information relating to the evaluation of Proposals and award recommendations shall not be disclosed to the Tenderers who submitted the Proposals or to any other party not officially concerned with the process, until the publication of the Contract award information.

22.2 Any attempt by Tenderers or any one on behalf of the Tenderer to influence improperly the Procuring Entity in the evaluation of the Proposals or Contract award decisions may result in the rejection of its Proposal and may be subject to the application of prevailing PPRA's debarment procedures.

[October 2024]

22.3 Notwithstanding the above provisions, from the time of the Proposals' opening to the time of Contract award publication, if a Tenderer wishes to contact the Procuring Entity on any matter related to the selection process, it should do so only in writing.

## **23 Opening of Technical Proposals**

23.1 The Procuring Entity's opening committee shall conduct the opening of the Technical Proposals in the presence of the Tenderers' authorized representatives who choose to attend (in person, or online if this option is offered in the Data Sheet). The opening date, time and the address are stated in the Data Sheet. The envelopes with the Financial Proposal shall remain sealed and shall be securely stored by the Procuring Entity or with a reputable public auditor or independent authority until they are opened.

23.2 At the opening of the Technical Proposals the following shall be read out:

- (i) the name and the country of the Tenderer or, in case of a Joint Venture, the name of the Joint Venture, the name of the lead member and the names and the countries of all members.
- (ii) the presence or absence of a duly sealed envelope with the Financial Proposal.
- (iii) (iii) any modifications to the Proposal submitted prior to proposal submission deadline; and
- (iv) (iv) any other information deemed appropriate or as indicated in the Data Sheet.

## **24 Proposals Evaluation**

24.1 The evaluators of the Technical Proposals shall have no access to the Financial Proposals until the technical evaluation is concluded and after the Procuring Entity notifies all the Tenderers in accordance with ITT 26.1.

24.2 The Tenderer is not permitted to alter or modify its Proposal in anyway after the proposal submission deadline except as permitted under ITT14.4. While evaluating the Proposals, the Evaluation Committee will conduct the evaluation solely on the basis of the submitted Technical and Financial Proposals.

[October 2024]

## **25 Evaluation of Technical Proposals**

25.1 The Procuring Entity's evaluation committee shall evaluate the Technical Proposals that have passed the eligibility and mandatory criteria, on the basis of their responsiveness to the Terms of Reference and the RFP.

In addition, the following criteria will also be considered and any other criteria that may be included in the data sheet.

- a) Tenderer has submitted the required number of copies of the Technical Proposals.
- b) Tenderer has submitted a sealed financial proposal.
- c) The Proposal is valid for the required number of days.
- d) The Technical Proposal is signed by the person with power of attorney, without material deviation, reservation, or omission.
- e) The Technical Proposal is complete with all the forms and required documentary evidence submitted.
- f) A valid tax compliance certificate or tax exemption certificate issued by the Kenya Revenue Authority.
- g) Key Staff are from eligible countries.
- h) Key Staff do not appear in more than one proposal.
- i) A short-listed firm has not participated in more than one proposal, if so required.
- j) The Tenderer is not insolvent, in receivership, bankrupt or in the process of being wound up.
- k) The Tenderer, its sub-Tenderers and experts have not engaged in or been convicted of corrupt or fraudulent practices.
- l) The Tenderer is neither precluded from entering into a Contract nor debarred by PPRA.
- m) The firm has not proposed employing public officials, civil servants and employees of public institutions.
- n) The Tenderer, its sub-Tenderers and experts have no conflicts of interest.

[October 2024]

25.2 Each responsive Proposal will be given a technical score. A Proposal shall be rejected at this stage if it does not respond to important aspects of the RFP or if it fails to achieve the minimum technical score indicated in the Data Sheet.

## **26 Public Opening of Financial Proposals**

### **26.1 Unsuccessful Proposals**

After the technical evaluation is completed, the Procuring Entity shall notify those Tenderers whose Proposals were considered non-responsive to the RFP and TOR or did not meet the minimum qualifying technical score, advising them the following:

- (i) Their Proposal was not responsive to the RFP and TOR or did not meet the minimum qualifying technical score.
- (ii) Provide information relating to the Tenderer's overall technical score, as well as scores obtained for each criterion and sub-criterion;
- (iii) Their Financial Proposals will be returned unopened after completing the selection process and Contract signing; and
- (iv) Notify them of the date, time and location of the public opening of the Financial Proposals and invite them to attend.

### **26.2 Financial Proposals**

Following the ranking of the Technical Proposals, and after internal approvals, the Procuring Entity shall simultaneously notify in writing those Tenderers whose Proposals were considered responsive to the RFP and TOR, and that have achieved the minimum qualifying technical score, advising them the following:

- (i) Their Proposal was responsive to the RFP and TOR and met the minimum qualifying technical score.
- (ii) Provide information relating to the Tenderer's overall technical score, as well as scores obtained for each criterion and sub-criterion.
- (iii) Their Financial Proposal will be opened at the public opening of Financial Proposals; and

[October 2024]

- (iv) Notify them of the date, time and location of the public opening and invite them for the opening of the Financial Proposals.

### 26.3 Opening of Financial Proposals

The opening date shall be at least One (1) Day from the date of notification of the results of the technical evaluation, described in ITT 23.1 and 23.2.

The Tenderer's attendance at the opening of the Financial Proposals (in person, or online if such option is indicated in the Data Sheet) is optional and is at the Tenderer's choice.

The Financial Proposals shall be opened publicly by the Procuring Entity in the presence of the representatives of the Tenderers and anyone else who chooses to attend. Any interested party who wishes to attend this public opening should contact the Procuring Entity as indicated in the Data Sheet.

At the opening, the names of the Tenderers and the overall technical scores shall be read aloud. The Financial Proposals will then be inspected to confirm that they have remained sealed and unopened. These Financial Proposals shall be then opened, and the total prices read aloud and recorded. Copies of the record shall be sent to all Tenderers who submitted Proposals.

### 26.4 Evaluation of Financial Proposals

The formulae for determining the Financial Score (Sf) shall be, as follows: -

$$Sf = 100 \times \frac{Fm}{F}$$

Where Sf is the financial score;  
Fm is the lowest priced financial proposal and  
F is the price of the proposal under consideration.

Proposals will be ranked according to their combined technical (*St*) and financial (*Sf*) scores using the weights;

*T* = Weight given to the Technical Proposal;

*P* = Weight given to the Financial Proposal; whereby  $T + P = 1$ .

The combined technical and financial score, *S*, is calculated as follows:

$$S = St \times T \% + Sf \times P \%$$

## 27 Correction of Errors

- 27.1 Activities and items described in the Technical Proposal but not priced in the Financial Proposal, shall be assumed to be included in the prices of other activities or items, and no corrections are made to the Financial Proposal.



[October 2024]

## **28 Taxes**

28.1 Subject to ITT 19.3, all taxes are deemed to be included in the Tenderer's financial proposal as separate items, and, therefore, considered in the evaluation.

28.2 All local identifiable taxes levied on the contract invoices (such as sales tax, VAT, excise tax, or any similar taxes or levies) and income and withholding tax payable to Kenya on the remuneration of non-resident Experts for the services rendered in Kenya are dealt with in accordance with the instructions in the Data Sheet.

## **29 Abnormally Low Prices**

29.1 An Abnormally Low Price is one where the financial price, in combination with other constituent elements of the proposal, appears unreasonably low to the extent that the price raises material concerns with the Procuring Entity as to the capability of the Consulting firm to perform the Contract for the offered price.

29.2 In the event of identification of a potentially Abnormally Low Price by the evaluation committee, the Procuring Entity shall seek written clarification from the Tenderer, including a detailed price analysis of its price in relation to the subject matter of the contract, scope, delivery schedule, allocation of risks and responsibilities and any other requirements of the RFP document.

29.3 After evaluation of the price analysis, if the Procuring Entity determines that the firm has failed to demonstrate its capability to perform the contract for the offered price, the Procuring Entity shall reject the firm's proposal.

## **30 Abnormally High Prices**

30.1 An abnormally high price is one where the proposal price, in combination with other constituent elements of the proposal, appears unreasonably too high to the extent that the Procuring Entity is concerned that it (the Procuring Entity) may not be getting value for money or it may be paying too high a price for the contract compared with market prices or that genuine competition between Tenderers is compromised.

30.2 In case of an abnormally high tender price, the Procuring Entity shall make a survey of the market prices, check if the estimated cost of the contract is correct, and review the RFP to check if the specifications, TOR, scope of work and conditions of contract are contributory to

[October 2024]

the abnormally high proposals. The Procuring Entity may also seek written clarification from the Tenderers on the reason or the high proposal price. The Procuring Entity shall proceed as follows:

- 30.3 If the proposal price is abnormally high based on wrong estimated cost of the contract, the Procuring Entity may accept or not accept the proposal depending on the Procuring Entity's budget considerations.
- 30.4 If specifications, TOR, scope of work and/or conditions of contract are contributory to the abnormally high proposal prices, the Procuring Entity shall reject all proposals and may re-invite for proposals for the contract based on revised estimates, specifications, TOR, scope of work and conditions of contract.
- 30.5 If the Procuring Entity determines that the Proposal Price is abnormally too high because genuine competition between Tenderers is compromised (often due to collusion, corruption or other manipulations), the Procuring Entity shall reject all Proposals and shall institute or cause competent Government Agencies to institute an investigation on the cause of the compromise, before re-inviting for proposals.

### **31 Unbalanced and/or Front-Loaded Tenders**

- 31.1 If in the Procuring Entity's opinion, the Tender that is evaluated as the lowest evaluated price is seriously unbalanced and/or front loaded, the Procuring Entity may require the Tenderer to provide written clarifications. Clarifications may include detailed price analyses to demonstrate the consistency of the tender prices with the scope of works, proposed methodology, schedule and any other requirements of the Tender document.
- 31.2 After the evaluation of the information and detailed price analyses presented by the Tenderer, the Procuring Entity may as appropriate:
- a. Accept the Tender; or
  - b. Require that the total amount of the Performance Security be increased at the expense of the Tenderer to a level not exceeding a10% of the Contract Price; or
  - c. Agree on a payment mode that eliminates the inherent risk of the Procuring Entity paying too much for undelivered works; or
  - d. Reject the Tender.

[October 2024]

### **32 Power of Attorney**

32.1 Each Tenderer shall provide a written power of attorney duly notarized, indicating that the person(s) signing the Tender has the authority to sign the Tender and thus that the Tender is binding upon the Tenderer during the full period of its validity.

### **33 Notification of Intention to enter into a Contract/Notification of Award**

33.1 The Procuring Entity shall send to each Tenderer (that has not already been notified that it has been unsuccessful) the Notification of Intention to Award the Contract to the successful Tenderer. The Notification of Intention to enter into a Contract / Notification of Award shall contain, at a minimum, the following information:

- i) The name and address of the Tenderer with whom the Procuring Entity successfully negotiated a contract.
- ii) The contract price of the successful Proposal.
- iii) A statement of the reasons why the recipient's Proposal was unsuccessful
- iv) The expiry date of the Standstill Period, and
- v) Instructions on how to request a debriefing and/or submit a complaint during the standstill period.

### **34 Standstill Period**

34.1 The Contract shall not be signed earlier than the expiry of a Standstill Period of 14 days to allow any dissatisfied tender to launch a complaint. Where only one Tender is submitted, the Stand still Period shall not apply.

34.2 Whereas Standstill Period applies, it shall commence when the Procuring Entity has transmitted to each tenderer the Notification of Intention to Enter into a Contract with the successful Tenderer.

## **D. NEGOTIATIONS AND AWARD**

### **35 Negotiations**

35.1 The negotiations will be held at the date and address indicated in the Data Sheet with the Tenderer's representative(s) who must have written power of attorney to negotiate and sign a Contract on behalf of the Tenderer.

35.2 The evaluation committee shall prepare minutes of negotiations that are signed by the Accounting Officer and the Tenderer's authorized representative.

[October 2024]

### **36 Availability of Key Staff**

- 36.1 The invited Tenderer shall confirm the availability of all Key Staff included in the Proposal as a pre-requisite to the negotiations. Failure to confirm the Key Staff' availability may result in the rejection of the Tenderer's Proposal and the Procuring Entity proceeding to negotiate the Contract with the next-ranked Tenderer.
- 36.2 Notwithstanding the above, the substitution Key Staff at the negotiations may be considered if due solely to circumstances outside the reasonable control of and not foreseeable by the Tenderer, including but not limited to death or medical incapacity. In such case, the Tenderer shall offer a substitute Key Expert within the period of time specified in the letter of invitation to negotiate the Contract, who shall have equivalent or better qualifications and experience than the original candidate.

### **37 Technical negotiations**

The technical negotiations include discussions of the Terms of Reference (TORs), the proposed methodology, the Procuring Entity's inputs, the special conditions of the Contract, and finalizing the "Description of Services" part of the Contract. These discussions shall not substantially alter the original scope of services under the TOR or the terms of the contract, lest the quality of the final product, its price, or the relevance of the initial evaluation be affected.

### **38 Financial negotiations**

- 38.1 The financial negotiations include the clarification of the Tenderer's tax liability in Kenya and how it should be reflected in the Contract. All applicable taxes shall be itemized separately and included in the contract price.

### **39 Conclusion of Negotiations**

- 39.1 The negotiations are concluded with a review of the finalized draft Contract, which then shall be initialed by the Accounting Officer and the Tenderer's authorized representative and minutes prepared to record the outcome of the negotiations.
- 39.2 If the negotiations fail, the Procuring Entity shall inform the Tenderer in writing of all pending issues and disagreements and provide a final opportunity to the Tenderer to respond. If disagreement persists, the Procuring Entity shall terminate the negotiations informing the

[October 2024]

Tenderer of the reasons for doing so. The Procuring Entity will invite the next-ranked Tenderer to negotiate a Contract. Once the Procuring Entity commences negotiations with the next-ranked Tenderer, the Procuring Entity shall not reopen the earlier negotiations.

#### **40 Letter of Award**

40.1 Upon expiry of the Standstill Period, after satisfactorily addressing any appeal that has been filed within the Standstill Period, and upon successful negotiations, the Procuring Entity shall send a Letter of Award to the successful Tenderer. The letter shall confirm the Procuring Entity's award of Contract to the successful Tenderer and requesting the Tenderer to sign and return the draft negotiated Contract within Twenty-One (21) Days from the date of the Letter of Award.

#### **41 Signing of Contract**

41.1 The Contract shall be signed prior to the expiration of the Proposal Validity Period and promptly after expiry of the Standstill Period, specified in ITT 29.1 and upon satisfactorily addressing any complaint that has been filed within the Standstill Period.

41.2 The Tenderer is expected to commence the assignment on the date and at the location specified in the Data Sheet.

#### **42 Publication of Procurement Contract**

42.1 Within the period specified in the Data Sheet, the Procuring Entity shall publish the awarded Contract which shall contain, at a minimum, the following information:

- (a) name and address of the Procuring Entity.
- (b) name and reference number of the contract being awarded,
- (c) the selection method used.
- (d) names of the Tenderers that submitted proposals.
- (e) names of all Tenderers whose Proposals were rejected or were not evaluated.
- (f) the name of the successful Tenderer, the final total contract price, the contract duration and a summary of its scope.

42.2 The awarded Contract shall be published on the Procuring Entity's website with free access if available and in the official procurement tender portal.

[October 2024]

**SECTION 2 (B). DATA SHEET**

<b>A. General Provisions</b>	
Reference to ITT Clause	
1(j)	<p>Electronic procurement system shall be used: (a) Yes .....(b) No (✓)</p> <p>If yes;</p> <p>Electronic - Procurement System</p> <p>The Procuring Entity shall use the following electronic-procurement system to manage this Request for Proposal process:</p> <p><b>[www.kenha.co.ke]</b></p> <p>The electronic-procurement system shall be used to manage the following part of the RFP process:</p> <p><b>[issuing of RFP, Clarifications and Addenda]</b></p>
2.1	<p>Name of the Procuring Entity: <b><u>Kenya National Highways Authority</u></b></p> <p>The Tenderer selection method is: <b>Quality and Cost Based Selection Method (QCBS)</b></p> <p>The formulae for determining the Financial Score (Sf) shall be, as follows: -</p> $Sf = 100 \times \frac{Fm}{F}$ <p>Where Sf is the financial score;</p> <p>Fm is the lowest priced financial proposal and</p> <p>F is the price of the proposal under consideration.</p>
2.2	<p><b>Financial Proposal to be submitted together with Technical Proposal in separate envelopes: Yes (✓) No ( )</b></p> <p>The name of the assignment is: <b>Management, Operation and Maintenance of Webuye Weighbridge Station and the 2073 Km Adjacent Road Network</b></p>
2.3	<p>Pre-Tender Site Visit will be held: Yes (✓) or No ( )</p> <p>Date of Pre-Tender Site Visit: <b>As per detailed Tender Notice</b></p> <p>A pre-proposal conference will be held: Yes (✓) or No ( )</p> <p>Date of pre-proposal conference: <b>As per detailed Tender Notice</b></p> <p>Address: <b>As per detailed Tender Notice</b></p>
2.4	<p>The Procuring Entity will provide the following inputs: project data, reports, etc. to facilitate the preparation of the Proposals</p>
7.2	<p>Maximum number of members in the Joint Venture (JV) shall be: <b>[Two]</b>.</p>

[October 2024]

7.6(a)	The list of debarred firms and individuals is available at the PPRA's website <b>www.ppra.go.ke</b> or email <b>complaints@ppra.go.ke</b>
7.7	Margin of Preference; Yes (√) or No ( ) Reservation; Open Tender for ALL
<b>B. Preparation of Proposals</b>	
11.1	<p>The Proposal shall comprise the following:</p> <p><b>1st Inner Envelope with the Technical Proposal: Power of Attorney to sign the Proposal</b></p> <p>FORM TECH-1: Form of tender - technical proposal submission form</p> <p>FORM ELI-1.1- Tenderer information form</p> <p>FORM ELI- 1.2- Tenderer JV information</p> <p>FORM TECH-2: Confidential Business Questionnaire</p> <p>FORM TECH-3: Conflict of interest disclosure</p> <p>FORM TECH-4: Certificate of independent proposal determination</p> <p>FORM SD 1: Self Declaration that the Person/Tenderer is not Debarred in the matter of the Public Procurement and Asset Disposal Act 2015</p> <p>FORM SD 2: Self Declaration that the tenderer will not engage in any corrupt or fraudulent practice</p> <p>FORM SD 3: Declaration and commitment to the code of ethics</p> <p>FORM TECH-6: Contractor's organization and experience</p> <p>FORM TECH-7: Comments and suggestions</p> <p>FORM TECH-8: Description of approach, methodology and work plan</p> <p>FORM TECH-9: Work Schedule</p> <p>FORM TECH-10: Financial Situation and Performance</p> <p>FORM TECH – 11: Average Annual Turnover</p> <p>FORM TECH 12: Current Contract Commitments / Works in Progress</p> <p>SCHEDULE A: Sub-Contractors / Partners</p> <p>FORM EQU: Contractor's Equipment</p> <p>FORM PER -1: Key Personnel Schedule</p> <p>Form PER -2 : Resume and Declaration – Key Personnel</p> <p>FORM PER 3: Curriculum Vitae (CV)</p> <p>FORMTECH-13: Mandatory Support Documents</p> <p>FORM TECH – 14: Form of Tender Security - Form of Demand Guarantee</p>

[October 2024]

	<p>FORM TECH - 15: Tender-Securing Declaration Form                  FORM TECH – 16: Form of Written Power of Attorney                  FORM TECH – 17: Historical Contract Non-Performance, Pending Litigation and Litigation History                  FORM TECH – 18: Declaration Form – Fair Employment Law and Practices                  FORM TECH 19: Declaration of knowledge of site                  APPENDIX TO FORM OF BID</p> <p><b>2nd Inner Envelope with the Financial Proposal:</b>                  FORM ELI- 1.3- 40% Percent Rule Form</p> <p><b>SECTION 4. Financial Proposal - Standard Forms</b>                  FORM OF TENDER                  FORM FIN-1: Financial Proposal Submission Form                  FORM FIN-2: Summary of Costs                  FORM FIN-3: Breakdown of Price Per Activity                  FORM FIN-4: Breakdown of Remuneration Per Activity</p>
12.1	<p>Participation of Sub-contractors, and Site Staff in more than one Proposal is permissible:                  Yes or No (√)</p> <p>Participation of Head Office Staff in more than one Proposal is permissible:                  Yes (√) or No</p>
13.1	<p>Proposals must remain valid for <b>[154] days</b> after the proposal submission deadline.</p>
14.1	<p>Clarifications may be requested no later than [7] days prior to the submission deadline.</p> <p>The contact information for requesting clarifications is:</p> <p style="text-align: center;"><b>Deputy Director – Supply Chain Management,                  Kenya National Highways Authority,                  P. O. Box 49712-00100, Nairobi                  Barabara Plaza, Jomo Kenyatta International Airport,                  Mazao Road, Off Airport North Road, Block C 2<sup>nd</sup> Floor</b></p> <p style="text-align: center;"><b>Email address: <i>procurement@kenha.co.ke, dracm@kenha.co.ke</i></b></p>
15 (c)	<p>Site Staff shall not appear in more than one proposal for same Bidder: Yes (√) or No</p>



[October 2024]

16.1	<p style="text-align: center;"><b>LOCATION AND ADDRESS OF DATAROOM</b></p> <p>The location of data room shall be the office of the Deputy Director, Supply Chain Management and the indicated electronic and physical address in 14.1 above.</p>
17.1	<p>A mandatory pre-proposal conference will be held: Yes (✓) or No</p> <p>Date of pre-proposal conference: <b>As per detailed Tender Notice</b></p> <p>Address: <b>As per detailed Tender Notice.</b></p>
19.2	A price adjustment provision for foreign and/or local inflation: Yes or No (✓)
19.3	<p>Information on the Contractor's tax obligations in the Procuring Entity's country can be found on the Kenya Revenue Authority website:</p> <p><b>www.kra.go.ke</b></p>
19.4	The Financial Proposal should state local costs in <b>Kenya Shillings</b>
<b>c. Submission, Opening and Evaluation</b>	
20.1	The Contractor [ <b>shall not</b> ] have the option of submitting their Proposals electronically.
20.5	<p>The Contractor must submit:</p> <p>Technical Proposal: <b>one (1) original</b></p> <p>Financial Proposal: <b>one (1) original</b></p>
21.5	<p>The Proposals must be submitted no later than:</p> <p>Date: <b>Thursday 28th November, 2024 at 11:00a.m. East African Time</b></p> <p style="text-align: center;"><b>Deputy Director – Supply Chain Management, Kenya National Highways Authority, P. O. Box 49712-00100, Nairobi Barabara Plaza, Jomo Kenyatta International Airport, Mazao Road, Off Airport North Road, Block C 2<sup>nd</sup> Floor</b></p>
23.1	<p>An online option of the opening of the Technical Proposals is offered:</p> <p>Yes ( ) or No (✓)</p> <p>The opening shall take place at Date: <b>Thursday 28th November, 2024 at 11:00a.m. East African Time</b></p> <p style="text-align: center;"><b>Kenya National Highways Authority, P. O. Box 49712-00100, Nairobi Barabara Plaza, Jomo Kenyatta International Airport, Mazao Road, Off Airport North Road, Block C 2<sup>nd</sup> Floor</b></p>
23.2	<p>In addition, the following information will be read aloud at the opening of the Technical Proposals,</p> <p><b>Name of the bidder</b></p>

[October 2024]

	<p><b>Number of documents submitted</b></p> <p><b>Number of pages in the document; whether or not serialised.</b></p>																																																
<p>25.1</p>	<p>The Criteria, sub-criteria, and point system for the evaluation of the Technical Proposals:</p> <p><b><u>Technical Evaluation Criteria</u></b></p> <table border="1" data-bbox="400 465 1366 842"> <thead> <tr> <th>Item No</th> <th>Description</th> <th>Points</th> </tr> </thead> <tbody> <tr> <td>1</td> <td>Organization, Methodology and Work plan</td> <td>30</td> </tr> <tr> <td>2</td> <td>Technological Innovation and their Applications to Axle Load Control</td> <td>25</td> </tr> <tr> <td>3</td> <td>Description and Qualifications of the Key Staff for the assignment</td> <td>25</td> </tr> <tr> <td>4</td> <td>ISO 17020:2012 Standard Accreditation -Type A</td> <td>10</td> </tr> <tr> <td>5</td> <td>Financial Standing</td> <td>10</td> </tr> </tbody> </table> <p>The minimum required experience in years of proposed staff and the points assigned to each is as shown hereunder: -</p> <table border="1" data-bbox="344 1005 1402 1792"> <thead> <tr> <th><i>Key Staff</i></th> <th><u>Experience required (Years)</u></th> <th><u>Maximum Points</u></th> </tr> </thead> <tbody> <tr> <td>Operations Manager</td> <td>5</td> <td>4</td> </tr> <tr> <td>Manager Weighbridge Cluster</td> <td>5</td> <td>3</td> </tr> <tr> <td>Technical Manager</td> <td>5</td> <td>3</td> </tr> <tr> <td>Assistant Weighbridge Manager</td> <td>3</td> <td>4</td> </tr> <tr> <td>Technicians (Computer and Information Technology)</td> <td>3</td> <td>1.5</td> </tr> <tr> <td>Technicians (Electromechanical)</td> <td>3</td> <td>2.5</td> </tr> <tr> <td>Systems Administrator/Control Room Operator</td> <td>3</td> <td>3</td> </tr> <tr> <td>Computer Operator Weighing</td> <td>3</td> <td>4</td> </tr> <tr> <td><b>Total</b></td> <td></td> <td><b>25</b></td> </tr> </tbody> </table> <p>The Weighbridge Station should have full staff presence for the 24 hours a day. The bidder therefore must factor in his rates the release staff for those proceeding on leave or off-duty.</p>	Item No	Description	Points	1	Organization, Methodology and Work plan	30	2	Technological Innovation and their Applications to Axle Load Control	25	3	Description and Qualifications of the Key Staff for the assignment	25	4	ISO 17020:2012 Standard Accreditation -Type A	10	5	Financial Standing	10	<i>Key Staff</i>	<u>Experience required (Years)</u>	<u>Maximum Points</u>	Operations Manager	5	4	Manager Weighbridge Cluster	5	3	Technical Manager	5	3	Assistant Weighbridge Manager	3	4	Technicians (Computer and Information Technology)	3	1.5	Technicians (Electromechanical)	3	2.5	Systems Administrator/Control Room Operator	3	3	Computer Operator Weighing	3	4	<b>Total</b>		<b>25</b>
Item No	Description	Points																																															
1	Organization, Methodology and Work plan	30																																															
2	Technological Innovation and their Applications to Axle Load Control	25																																															
3	Description and Qualifications of the Key Staff for the assignment	25																																															
4	ISO 17020:2012 Standard Accreditation -Type A	10																																															
5	Financial Standing	10																																															
<i>Key Staff</i>	<u>Experience required (Years)</u>	<u>Maximum Points</u>																																															
Operations Manager	5	4																																															
Manager Weighbridge Cluster	5	3																																															
Technical Manager	5	3																																															
Assistant Weighbridge Manager	3	4																																															
Technicians (Computer and Information Technology)	3	1.5																																															
Technicians (Electromechanical)	3	2.5																																															
Systems Administrator/Control Room Operator	3	3																																															
Computer Operator Weighing	3	4																																															
<b>Total</b>		<b>25</b>																																															

[October 2024]

	<p>The number of points to be assigned to each of the above Key personnel shall be determined as follows:</p> <p><b>Key Personnel</b></p> <p><b>1. Operations Manager</b> (max. 4 points)</p> <p>Qualification and Skills 1</p> <p>General professional experience 1</p> <p>Specific professional experience 2</p> <p><b>2. Technical Manager</b> (max. 3 points)</p> <p>Qualification and Skills 0.5</p> <p>General professional experience 0.5</p> <p>Specific professional experience 1</p> <p>Repairer's license (Type 3) by Weights and Measures Department 1</p> <p><b>3. Certified Technicians (Electro-mechanical)</b> (Max. 2.5 points)</p> <p>Qualification and Skills 0.5</p> <p>General professional experience 0.5</p> <p>Specific professional experience 0.5</p> <p>Repairer's license (Type 3) by Weights and Measures Department 1</p> <p>and Measures Department</p> <p><b>4. Technicians (Computer and Information Technology)</b> (Max. 1.5 points)</p> <p>Qualification and Skills 0.5</p> <p>General professional experience 0.5</p> <p>Specific professional experience 0.5</p> <p><b>5. Manager Weighbridge Cluster</b> (max. 3 points)</p> <p>Qualification and Skills 0.5</p> <p>General professional experience 1</p> <p>Specific professional experience 1.5</p> <p><b>6. Assistant Weighbridge Manager</b> (Max. 4 points)</p> <p>Qualification and Skills 1</p> <p>General professional experience 1</p> <p>Specific professional experience 2</p>
--	--

[October 2024]

**7. Systems Administrator/Control Room Operator** (max. 3 points)

Qualification and Skills 1

General professional experience 1

Specific professional experience 1

**8. Computer Operator Weighing** (Max. 4 points)

Qualification and Skills 1

General professional experience 1

Specific professional experience 2

**Total score for Key Personnel** 25

The Evaluation grid (score sheet) is shown below will be used to determine the adequacy and quality of the proposed methodology, and work plan in responding to the Terms of Reference (TORs):

**Evaluation Grid**

<b>Organisation, Methodology and Workplan</b>	
<b>ITEM</b>	<b>Maximum Score</b>
Rationale	5
Strategy for Implementation	15
Resourced Schedule of activities	10
<b>Total</b>	<b>30</b>

Maximum score = 30

<b>Technological Innovation and their Applications to Axle Load Control</b>	
<b>ITEM</b>	<b>Maximum Score</b>
Weighbridge Maintenance Schedules	5
Modern Weighing Systems and Accessories	10
Hardware, Software Proposals, Upgrades and Integration	5
Proposed Innovations and how they would Impact Axle Load Compliance	5
<b>Total</b>	<b>25</b>

[October 2024]

	<p>Maximum score = 25</p> <p><b>ISO/IEC 17020:2012 Standard Accreditation -Type A (Provide ISO Certificate from Accrediting Body). In case of a Joint Venture (JV), each member shall provide ISO/IEC 17020:2012 Standard Accreditation -Type A</b></p> <p>Score= 0 or 10 marks</p> <p><b>Financial standing</b></p> <p>Maximum Score=10</p> <p><i>*See Part 2 of Form TECH 10</i></p> <table border="1" data-bbox="395 685 1426 837"> <thead> <tr> <th>ITEM</th> <th>MAXIMUM SCORE</th> </tr> </thead> <tbody> <tr> <td>Financial Standing</td> <td>4</td> </tr> <tr> <td>Working Capital</td> <td>6</td> </tr> <tr> <td><b>Total</b></td> <td><b>10</b></td> </tr> </tbody> </table> <p><b>Total Score for Technical Proposal = 100</b></p> <p>Other eligibility and mandatory criteria shall be: As indicated in the <b>TOR</b></p>	ITEM	MAXIMUM SCORE	Financial Standing	4	Working Capital	6	<b>Total</b>	<b>10</b>
ITEM	MAXIMUM SCORE								
Financial Standing	4								
Working Capital	6								
<b>Total</b>	<b>10</b>								
<p>25.2</p>	<p><i>The minimum technical score required to pass is 70%</i></p> <p><i>The weights of the overall scores are as follows: -</i></p> <p><b>T= 70 (Technical Proposal weight of scores)</b></p> <p><b>P=30 Financial Weight of Scores</b></p>								
<p>26.3</p>	<p>Any interested party who wishes to attend this public opening may contact [insert name and contact details for responsible officer] and request to be notified of the location, date and time of the public opening of Financial Proposals. The request should be made before the deadline for submission of Tenders, stated above. The opening of the Financial Part shall take place at:</p> <p style="text-align: center;"><b>Kenya National Highways Authority, P. O. Box 49712-00100, Nairobi Barabara Plaza, Jomo Kenyatta International Airport, Mazao Road, Off Airport North Road, Block C 2<sup>nd</sup> Floor</b></p> <p>The Form of Tender - Financial Proposal shall be initialled by [insert number] representatives of the Procuring Entity conducting Tender opening. [Insert procedure: Example: Each Tender shall be initialled by all representatives and shall be numbered. ]</p>								
<p>28.2</p>	<p>Taxes:</p> <p><b>The Contractor shall be liable to pay all taxes, duties and levies including VAT and withholding tax in accordance with the laws of</b></p>								

[October 2024]

	<b>Kenya and the Client shall not reimburse any amount paid in this context.</b>
<b>d.</b>	<b>Negotiations and Award</b>
40.2	The assignment is expected to commence within <i>14 (fourteen) days after signing of the contract by all parties.</i>

[October 2024]

## SECTION 3- EVALUATION AND QUALIFICATION CRITERIA

### General Provisions

#### 1 General Provisions

- 1.1 This section contains the criteria that the Employer shall use to evaluate tender and qualify tenderers. No other factors, methods or criteria shall be used other than specified in this tender document. The Tenderer shall provide all the information requested in the forms included in Section IV, Tendering Forms. The Procuring Entity shall use **the Standard Tender Evaluation Document for Management Services** for evaluating Tenders.
- 1.2 Wherever a Tenderer is required to state a monetary amount, Tenderers should indicate the Kenya Shilling equivalent using the rate of exchange determined as follows:
  - a) For turnover or financial data required for each year - Exchange rate prevailing on the last day of the respective calendar year (in which the amounts for that year is to be converted) was originally established.
  - b) Value of single contract - Exchange rate prevailing on the date of the contract signature.
  - c) Exchange rates shall be taken from the Central Bank of Kenya website. Any error in determining the exchange rates in the Tender may be corrected by the Procuring Entity.

#### 2. Evaluation and contract award Criteria

The Procuring Entity shall use the criteria and methodologies listed in this Section to evaluate tenders and arrive at the Lowest Evaluated Tender. The tender that (i) meets the qualification criteria, (ii) has been determined to be substantially responsive to the Tender Documents, and (iii) is determined to have the Lowest Evaluated Tender price shall be selected for award of contract.

##### **Preliminary examination for Determination of Responsiveness**

The Procuring Entity will start by examining all tenders to ensure they meet in all respects the eligibility criteria and other requirements in the ITT, and that the tender is complete in all aspects in meeting the requirements of “*Form Tech 13 – Mandatory Preliminary Requirements*”, including checking for tenders with unacceptable errors, abnormally low tenders, abnormally high tenders and tenders that are front loaded. Tenders that do not pass the Preliminary Examination will be considered unresponsive and will not be considered further.

*[The Procuring Entity will provide the preliminary evaluation criteria. To facilitate, a template may be attached or clearly described all information and list of documentation to be submitted by Tenderers to enable preliminary evaluation of the Tender]*

##### **Multiple Contracts**

Multiple contracts will be permitted. Tenderers are evaluated on basis of Lots (Clusters) and the lowest evaluated tenderer identified for each Lot (Cluster). The Procuring Entity will select one Option of the two Options listed below for award of Contracts.

*For this purpose, Lot(s) and Cluster(s) are used interchangeably.*

##### **OPTION 1**

- i) If a tenderer wins only one Lot, the tenderer will be awarded a contract for that Lot, provided the tenderer meets the Eligibility and Qualification Criteria for that Lot.

[October 2024]

- ii) If a tenderer wins more than one Lot, the tender will be awarded contracts for all won Lots, provided the tenderer meets the aggregate Eligibility and Qualification Criteria for all the Lots. The tenderer will be awarded the combination of Lots for which the tenderer qualifies and the others will be considered for award to the second lowest tenderers. *For a bidder winning multiple Lots, only upto a maximum of two(2) Lots(Clusters) would be considered for award based on which combination of Lots is most advantageous to the Procuring entity*

## **OPTION 2**

The Procuring Entity will consider all possible combinations of won Lots [contract(s)] and determine the combinations with the lowest evaluated price. Tenders will then be awarded to the Tenderer or Tenderers in the combinations provided the tenderer meets the aggregate Eligibility and Qualification Criteria for all the won Lots. *For a bidder winning multiple Lots, only upto a maximum of two(2) Lots(Clusters) would be considered for award based on which combination of Lots is most advantageous to the Procuring entity.*

### **Margin of Preference**

- 1.1 If the TDS so specifies, the Procuring Entity will grant a margin of preference of fifteen percent (15%) to be loaded on the evaluated price of the foreign tenderers, where the percentage of shareholding of Kenyan citizens is less than fifty-one percent (51%).
- 1.2 Contractors applying for such preference shall be asked to provide, as part of the data for qualification, such information, including details of ownership, as shall be required to determine whether, according to the classification established by the Procuring Entity, a particular contract or group of contractors qualifies for a margin of preference.
- 1.3 After Tenders have been received and reviewed by the Procuring Entity, responsive Tenders shall be assessed to ascertain their percentage of shareholding of Kenyan citizens. Responsive tenders to shall be classified into the following groups:
  - i) Group A: tenders offered by Kenyan Contractors and other Tenderers where Kenyan citizens hold shares of over fifty one percent (51%).
  - ii) Group B: tenders offered by foreign Contractors and other Tenderers where Kenyan citizens hold shares of less than fifty one percent (51%).
- 1.4 All evaluated tenders in each group shall, as a first evaluation step, be compared to determine the lowest tender, and the lowest evaluated tender in each group shall be further compared with each other. If, as a result of this comparison, a tender from Group A is the lowest, it shall be selected for the award. If a tender from Group B is the lowest, an amount equal to the percentage indicated in Item 3.1 of the respective tender price, including unconditional discounts and excluding provisional sums and the cost of day works, if any, shall be added to the evaluated price offered in each tender from Group B. All tenders shall then be compared using new prices with added prices to Group Band the lowest evaluated tender from Group A. If the tender from Group A is still the lowest tender, it shall be selected for award. If not, the lowest evaluated tender from Group B based on the first evaluation price shall be selected.

### **3. Tender Evaluation**

**Price evaluation:** Tenders will be evaluated as specified in ITT 26.4

### **4. Post qualification and Contract award**



[October 2024]

- a) In case the tender was subject to post-qualification, the contract shall be awarded to the lowest evaluated tenderer, subject to confirmation of pre-qualification data, if so required.
- b) In case the tender was not subject to post-qualification, the tender that has been determined to be the lowest evaluated tenderer shall be considered for contract award, subject to meeting each of the following conditions.
  - i) The Tenderer shall demonstrate that it has access to, or has available, liquid assets, unencumbered real assets, lines of credit, and other financial means (independent of any contractual advance payment) sufficient to meet the construction cash flow of Kenya Shillings.
  - ii) At least 2 contract(s) of a similar nature executed within Kenya, or the East African Community or abroad, that have been satisfactorily and substantially completed as a prime contractor, or joint venture member or sub-contractor each of minimum value Kenya shillings One Hundred Million Only.
  - iii) Contractor's Representative and Key Personnel.
  - iv) Contractors' key equipment listed on the table "Contractor's Equipment" below and more specifically listed as *[specify requirements for each lot as applicable]*

No.	Equipment Type and Characteristics	Minimum Number required
1		
2		
3		
4		
...		

**c) History of non-performing contracts:**

Tenderer and each member of JV incase the Tenderer is a JV, shall demonstrate that Non-performance of a contract did not occur because of the default of the Tenderer, or the member of a JV in the last **3 YEARS**. The required information shall be furnished in the appropriate form.

**d) Pending Litigation**

Financial position and prospective long-term profitability of the Single Tenderer, and in the case the Tenderer is a JV, of each member of the JV, shall remain sound according to criteria established with respect to Financial Capability under Paragraph (i) above if all pending litigation will be resolved against the Tenderer. Tenderer shall provide information on pending litigations in the appropriate form.

**e) Litigation History**

There shall be no consistent history of court/arbitral award decisions against the Tenderer, in the last 3 years. All parties to the contract shall furnish the information in the appropriate form about any litigation or arbitration resulting from contracts completed or ongoing under its execution over the years specified. A consistent history of awards against the Tenderer or any member of a JV may result in rejection of the tender.

The eligibility and mandatory criteria shall include the items in the table below.

[October 2024]

**PRELIMINARY REQUIREMENTS (MANDATORY)**

<b>S / No</b>	<b>Completeness &amp; Responsiveness Criteria</b>	<b>References</b>	<b>Requirement</b>
1.	Form of Bid	Bid Document	<ul style="list-style-type: none"> <li>- Amount MUST be Indicated</li> <li>- Properly Fill &amp; sign (To be submitted with the Financial Proposal)</li> </ul>
2.	Appendix to Form of Bid	Bid Document	<ul style="list-style-type: none"> <li>- Form Properly Signed (To be submitted with the Technical Proposal)</li> </ul>
3.	Tender Security	Bid Document - Form TECH 14	<ul style="list-style-type: none"> <li>- Unconditional Bank Guarantee (In the Format provided with ALL Conditions)</li> <li>- KSh. 750,000.00 in the form of unconditional bank guarantee</li> </ul>
4.	Confidential Business Questionnaire	Form TECH 2	<ul style="list-style-type: none"> <li>- Properly Fill &amp; Sign</li> <li>- Provide ALL Required Information</li> </ul>
5.	Form of Power of Attorney	Form TECH-16	<ul style="list-style-type: none"> <li>- Properly Fill &amp; Sign</li> <li>- Provide Copies of National Identification Card / Passport</li> </ul>
6.	Tax Compliance Certificate	Form TECH 13	<ul style="list-style-type: none"> <li>- Copy of Certificate</li> <li>- Valid as per KRA TCC Checker</li> </ul>
7.	Copy of recent CR 12 form	Form ELI 1.1	<ul style="list-style-type: none"> <li>- Copy of certificate issued within the last six (6) months</li> </ul>
8.	Serialization of Submitted Bid Document	Employer's Notice	<ul style="list-style-type: none"> <li>- Bidders shall sequentially serialize all pages of each tender submitted. Any written Pages or document attached or inserted Documents MUST be sequentially serialized.</li> </ul>
9.	Certificate of Approval for Repairers Workshop (Type 3) Registration with the Department of Weights and Measures	Employer's Notice	<ul style="list-style-type: none"> <li>- Copy of Certificate Valid</li> </ul>
10.	Certificate of Incorporation/Registration	Form TECH 13	<ul style="list-style-type: none"> <li>- Copy of certificate</li> </ul>
11.	Priced Bill of Quantities	Form FIN 4	<ul style="list-style-type: none"> <li>- Fill all rates, prices and amounts,</li> <li>- NO Alterations of the Quantities accepted,</li> <li>- All bidders own Corrections must be Countersigned</li> <li>- No Errors noted in the Bills of Quantities</li> </ul>

[October 2024]

12.	Eligibility	Employer's Notice	Copies of National ID / Passport for All Directors
13.	Conflict of Interest Disclosure	Form TECH-3	To State Explicitly
14.	Pre-Bid Conference	ITT 17.1	- Attend Pre-Tender Site Visits and Pre-proposal Conference - Bidders to Sign Attendance Register
15.	Contractor's Equipment	Form EQU	Properly Fill & Sign
16.	Goods, equipment and services to be supplied under the contract	Form ELI 1.3	- Declarations of Materials, Equipment and Labour Sources - Properly filled & signed
17.	Contractor's Organization and Experience	Form TECH 6	Properly Fill & Sign
18.	Current Contract Commitments	Form TECH 12	Properly Fill & Sign
19.	Schedule of Other Supplementary Information / Financial Standings	Schedule 6	- Properly Fill & Sign - Audited Accounts for Three (3) Years Certified by a CPAK - Bank Statement for Last Six (6) Months and Evidence of Access to Credit from a financial institution
20.	PPRA Eligibility	Form TECH 5	- Form of Tender - <b>Form SD 1</b> - properly filled & signed
21.	Joint Ventures	ITT 7.2	- All Joint Venture Partners MUST meet all Mandatory requirements as stipulated in the tender document. - The bidder shall provide evidence of a duly executed joint venture agreement by both parties and registration of the same in line with the Registration of Documents Act.
22.	Completeness of the tender document.	ITT 20.2	- All pages with entries (typed or hand written) must be initialized. Any alterations made in the Tender document must be countersigned. - Filling of Schedules/Forms/Tables (All forms/schedules that are required to filled, signed and dated)

**Certificates/Licenses may be verified from or with the Issuing Authorities or Agencies.**

[October 2024]

### **Other Requirements**

As specified in the tender documents covering the following: -

1. Similar previous experience
2. Professional and technical personnel
3. Current work load
4. Litigation history (**Current** Sworn Affidavit) within the last three (3) months
5. Eligibility
  - a. To enhance equity, bidders shall bid for a maximum of **Three (3)** Tenders, but can only be Awarded a Maximum of **Two (2)** Tenders, under this Tender Notice. Bidders who participate in more than **Three (3)** tenders shall be disqualified. **In the event that a bidder has the highest combined score in more than one bid, they will be awarded the bids that offer the highest savings in reference to the Procuring Entity's own cost estimates.**
  - b. Director (s) bidding under different companies for the same tender shall be disqualified
  - c. Director (s) bidding under different companies should not participate in more than **Three (3)** tenders
  - d. Bidders to comply with Section 157 of the Public Procurement and Asset Disposal Act, 2015 (PPADA, 2015) on participation of candidates in preference and reservations.
  - e. Any form of Canvassing will lead to disqualification

[October 2024]

## SECTION 4. TECHNICAL PROPOSAL – STANDARD FORMS

### FORM TECH-1: FORM OF TENDER - TECHNICAL PROPOSAL SUBMISSION FORM

- (i) The Tenderer must prepare this Form of Tender on stationery with its letterhead clearly showing the Tenderer's complete name and business address.
- (ii) All italicized text is to help Tenderer in preparing this form.
- (iii) Tenderer must complete and sign and TENDERER'S ELIGIBILITY- CONFIDENTIAL BUSINESS QUESTIONNAIRE, CERTIFICATE OF INDEPENDENT TENDER DETERMINATION and the SELF DECLARATION OF THE TENDERER, all attached to this Form of Tender.

**Date of this Tender submission:** ..... *[Insert date (as day, month and year) of Tender submission]*

**ITT No.:** ..... *[Insert number of Tendering process]*

**To: Kenya National Highways Authority**

We, the undersigned Tenderer, hereby submit our

Tender, in two parts, namely:

- i) The Technical Proposal, and
- ii) The Financial Proposal.

In submitting our Tender, we make the following declarations:

- a) **No reservations:** We have examined and have no reservations to the Tendering Document, including Addenda issued in accordance with Instructions to Tenderers
- b) **Eligibility:** We meet the eligibility requirements and have no conflict of interest.
- c) **Tender-Securing Declaration:**  
We have not been debarred by the Authority based on execution of a Tender-Securing Declaration or Tender Securing Declaration in Kenya.
- d) **Conformity:** We offer to supply in conformity with the Tendering Document and in accordance with the Schedules specified in the Terms of Reference for this Contract.
- e) **Tender Validity Period:** Our Tender shall be valid for the period specified in TDS ITT 13.1 from the date fixed for the Tender submission deadline specified in TDS ITT 21.5 (as amended, if applicable), and it shall remain binding upon us, and may at any time before the expiration of that period;
- f) **Performance Security:** If our Tender is accepted, we commit to obtain a performance security in accordance with the Tendering Document;
- g) **One Tender per Tenderer:** We are not submitting any other Tender(s) as an individual Tenderer, and we are not participating in any other Tender(s) as a Joint Venture member or as a subcontractor.
- h) **Suspension and Debarment:** We, along with any of our subcontractors, suppliers, consultants, manufacturers, or service providers for any part of the contract, are not subject to, and not controlled by any entity or individual that is subject to, a temporary suspension or a debarment imposed by the PPRA. Further, we are not ineligible under

[October 2024]

the Kenya laws or official regulations or pursuant to a decision of the United Nations Security Council;

- i) **State-owned enterprise or institution:** [*We are not a state- owned enterprise or institution*]/ [*We are a state-owned enterprise or institution but meet the requirements of ITT 4.7*]
- j) **Binding Contract:** We understand that this Tender, together with your written acceptance thereof included in your Form of Acceptance, shall constitute a binding contract between us, until a formal contract is prepared and executed;
- k) **Not Bound to Accept:** We understand that you are not bound to accept the lowest evaluated cost Tender, the Lowest Evaluated Tender or any other Tender that you may receive; and
- l) **Fraud and Corruption:** We hereby certify that we have taken steps to ensure that no person acting for us or on our behalf engages in any type of Fraud and Corruption.
- m) We undertake to adhere by the Code of Ethical Conduct for Persons Participating in Public Procurement and Asset Disposal Activities in Kenya, copy available from [www.ppra.go.ke](http://www.ppra.go.ke) during the procurement process and the execution of any resulting contract.
- n) We, the Tenderer, have fully completed and signed the following Forms as part of our Tender:
  - i) Tenderer's Eligibility; Confidential Business Questionnaire – to establish we are not in any conflict to interest.
  - ii) Certificate of Independent Tender Determination – to declare that we completed the tender without colluding with other tenderers.
  - iii) Self-Declaration of the Tenderer–to declare that we will, if awarded a contract, not engage in any form of fraud and corruption.
  - iv) Declaration and commitment to the code of ethics for Persons Participating in Public Procurement and Asset Disposal Activities in Kenya,

Further, we confirm that we have read and understood the full content and scope of fraud and corruption as informed in “**Appendix 1- Fraud and Corruption**” attached to the Form of Tender.

**Name of the Tenderer:** \*[insert complete name of Tenderer]

**Name of the person duly authorized to sign the Tender on behalf of the Tenderer:** \*\*  
[insert complete name of person duly authorized to sign the Tender]

**Title of the person signing the Tender:** \_\_\_\_\_

**Signature of the person named above:** \_\_\_\_\_

**Date signed** \_\_\_\_\_ **day of** \_\_\_\_\_ [insert year]

\*: In the case of the Tender submitted by a Joint Venture specify the name of the Joint Venture as Tenderer.

\*\* : Person signing the Tender shall have the power of attorney given by the Tenderer. The power of attorney shall be attached with the Tender Schedules.

[October 2024]

**TENDERER'S QUALIFICATION FORMS**

**1 FORM ELI-1.1- TENDERER INFORMATION FORM**

<b>Form ELI-1.1</b>
<b>Tenderer Information Form</b>
Date: _____
ITT No. and title: _____
Page _____ of _____ pages
Tenderer's name: .....
In case of Joint Venture (JV), name of each member:.....
Tenderer's actual or intended country of registration: <i>[indicate country of Constitution]</i>
Tenderer's actual or intended year of incorporation:
Tenderer's legal address [in country of registration]:
Tenderer's authorized representative information Name: _____ Address: _____ Telephone/Fax numbers: _____ E-mail address: _____
1. Attached are copies of original documents of:  I. <i>Certificate of Incorporation and CR12</i> of the legal entity named above, in accordance with ITT 25.1.  II. <i>Copies of National Identification documents for Directors</i>  <input type="checkbox"/> In case of a JV, Form of intent to form JV or JV agreement, in accordance with ITT 7.2. <input type="checkbox"/> In case of a state-owned enterprise or institution, in accordance with ITT 7.6. documents establishing: <ul style="list-style-type: none"><li>• Legal and financial autonomy</li><li>• Operation under commercial law</li><li>• Establishing that tenderer is not under the supervision of the Procuring Entity,</li></ul>
2. Included are the organizational chart, a list of Board of Directors, and the beneficial ownership ( <i>Not Applicable</i> ).

[October 2024]

## 2 FORM ELI- 1.2- TENDERER JV INFORMATION

Tenderer's JV Information Form

(to be completed for each member of Tenderer's JV)

Date: \_\_\_\_\_ ITT No. and title:

\_\_\_\_\_ Page \_\_\_\_ of \_\_\_\_ pages

Tenderer's JV name:
JV member's name:
JV member's country of registration:
JV member's year of constitution:
JV member's legal address in country of constitution:
JV member's authorized representative information Name: _____ Address: _____ Telephone/Fax numbers: _____ E-mail address: _____
1. Attached are copies of original documents of: <ul style="list-style-type: none"><li>i. Certificate of Incorporation and CR 12 of the legal entity named above, including Registered JV agreement (Registration of Documents Act), in accordance with ITT 25.1.</li><li>ii. Copies of National Identification documents for all Directors</li></ul> <input type="checkbox"/> In case of a state-owned enterprise or institution, documents establishing legal and financial autonomy, operation in accordance with commercial law, and that they are not under the supervision of the Procuring Entity, in accordance with ITT 7.6.
2. Included are the organizational chart, a list of Board of Directors, and the beneficial ownership ( <i>Not Applicable</i> ).



[October 2024]

**FORM TECH-2: CONFIDENTIAL BUSINESS QUESTIONNAIRE  
TENDERER'S ELIGIBILITY**

**a) Instructions to Tenderer**

Tenderer is instructed to complete the particulars required in this Form, *one form for each entity if Tenderer is a JV*. Tenderer is further reminded that it is an offence to give false information on this Form.

Tenderer's details

	ITEM	DESCRIPTION
1	Name of the Procuring Entity	Kenya National Highways Authority
2	Name of the Tenderer	
3	Full Address and Contact Details of the Tenderer.	1.Country 2. City 3.Location 4. Building 5.Floor 6. Postal Address 7. Name and email of contact person.
4	Reference Number of the Tender	
5	Date and Time of Tender Opening	
6	Current Trade License No and Expiring date	
7	Maximum value of business which the Tenderer handles.	

**General and Specific Details**

**a) Sole Proprietor, provide the following details.**

Name in full \_\_\_\_\_

Age \_\_\_\_\_

Nationality \_\_\_\_\_

Country of Origin \_\_\_\_\_

Citizenship \_\_\_\_\_

[October 2024]

b) **Partnership**, provide the following details.

	Names of Partners	Nationality	Citizenship	% Shares owned
1				
2				
3				

c) **Registered Company**, provide the following details.

i) Private or public Company \_\_\_\_\_

ii) State the nominal and issued capital of the Company-

Nominal Kenya Shillings (Equivalent).....

Issued Kenya Shillings (Equivalent).....

iii) Give details of Directors as follows

	Names of Director	Nationality	Citizenship	% Shares owned
1				
2				
3				

**DISCLOSURE OF INTEREST- Interest of the Firm in the Procuring Entity.**

i) Are there any person/persons in KeNHA who has an interest or relationship in this firm?

Yes/No.....

If yes, provide details as follows.

	Names of Person	Designation in the Procuring Entity	Interest or Relationship with Tenderer
1			
2			
3			

[October 2024]

**FORM TECH-3: CONFLICT OF INTEREST DISCLOSURE**

	Type of Conflict	Disclosure YES OR NO	If YES provide details of the relationship with Tenderer
1	Tenderer is directly or indirectly controls, is controlled by or is under common control with another tenderer.		
2	Tenderer receives or has received any direct or indirect subsidy from another tenderer.		
3	Tenderer has the same legal representative as another tenderer		
4	Tender has a relationship with another tenderer, directly or through common third parties, that puts it in a position to influence the tender of another tenderer, or influence the decisions of the Procuring Entity regarding this tendering process.		
5	Any of the Tenderer’s affiliates participated as a consultant in the preparation of the design or technical specifications of the works that are the subject of the tender.		
6.	Tenderer would be providing goods, works, non-consulting services or consulting services during implementation of the contract specified in this Tender Document.		
7	Tenderer has a close business or family relationship with a professional staff of the Procuring Entity who are directly or indirectly involved in the preparation of the Tender document or specifications of the Contract, and/or the Tender evaluation process of such contract.		
8	Tenderer has a close business or family relationship with a professional staff of the Procuring Entity who would be involved in the implementation or supervision of the such Contract.		
9	Has the conflict stemming from such relationship stated in item 7 and 8 above been resolved in a manner acceptable to the Procuring Entity throughout the tendering process and execution of the Contract.		

**Certification**

On behalf of the Tenderer, I certify that the information given above is correct.

Full Name \_\_\_\_\_

Title or Designation \_\_\_\_\_

\_\_\_\_\_  
(Signature)

\_\_\_\_\_  
(Date)

[October 2024]

**FORM TECH-4: CERTIFICATE OF INDEPENDENT PROPOSAL DETERMINATION**

I, the undersigned, in submitting the accompanying TECHNICAL PROPOSAL SUBMISSION FORM to **Kenya National Highways Authority**

For: **Management, Operation and Maintenance of Webuye Weighbridge Station and the 2073 Km Adjacent Road Network.**

\_\_\_\_\_ [Name and number of tender] in response to the request for tenders made by: \_\_\_\_\_ [Name of Tenderer] do hereby make the following statements that I certify to be true and complete in every respect:

I certify, on behalf of \_\_\_\_\_ [Name of Tenderer] that:

1. I have read and I understand the contents of this Certificate;
2. I understand that the Tender will be disqualified if this Certificate is found not to be true and complete in every respect;
3. I am the authorized representative of the Tenderer with authority to sign this Certificate, and to submit the Tender on behalf of the Tenderer;
4. For the purposes of this Certificate and the Tender, I understand that the word “competitor” shall include any individual or organization, other than the Tenderer, whether or not affiliated with the Tenderer, who:
  - a) Has been requested to submit a Tender in response to this request for tenders;
  - b) could potentially submit a tender in response to this request for tenders, based on their qualifications, abilities or experience;
5. The Tenderer discloses that [check one of the following, as applicable]:
  - a) The Tenderer has arrived at the Tender independently from, and without consultation, communication, agreement or arrangement with, any competitor;
  - b) the Tenderer has entered into consultations, communications, agreements or arrangements with one or more competitors regarding this request for tenders, and the Tenderer discloses, in the attached document(s), complete details thereof, including the names of the competitors and the nature of, and reasons for, such consultations, communications, agreements or arrangements;
6. In particular, without limiting the generality of paragraphs (5) (a) or (5) (b) above, there has been no consultation, communication, agreement or arrangement with any competitor regarding:
  - a) prices;
  - b) methods, factors or formulas used to calculate prices;
  - c) the intention or decision to submit, or not to submit, a tender; or
  - d) the submission of a tender which does not meet the specifications of the request for Tenders; except as specifically disclosed pursuant to paragraph (5) (b) above;

[October 2024]

7. In addition, there has been no consultation, communication, agreement or arrangement with any competitor regarding the quality, quantity, specifications or delivery particulars of the works or services to which this request for tenders relates, except as specifically authorized by the procuring authority or as specifically disclosed pursuant to paragraph (5) (b) above;
8. the terms of the Tender have not been, and will not be, knowingly disclosed by the Tenderer, directly or indirectly, to any competitor, prior to the date and time of the official tender opening, or of the awarding of the Contract, whichever comes first, unless otherwise required by law or as specifically disclosed pursuant to paragraph (5) (b) above.

Name \_\_\_\_\_

Title \_\_\_\_\_

Date \_\_\_\_\_

*[Name, title and signature of authorized agent of Tenderer and Date]*

[October 2024]

**FORM TECH-5. SELF-DECLARATION FORMS**

**FORM SD 1: SELF DECLARATION THAT THE PERSON/TENDERER IS NOT DEBARRED IN THE MATTER OF THE PUBLIC PROCUREMENT AND ASSET DISPOSAL ACT 2015**

I, ....., of Post Office Box.....being a resident of .....in the Republic of.....do hereby make a statement as follows:

-

1. THAT I am the Company Secretary/ Chief Executive/Managing Director/Principal Officer/Director of ..... (*insert name of the Company*) who is a Bidder in respect of Tender No.....for.....(*insert tender title/description*) for..... (*insert name of the Procuring entity*) and duly authorized and competent to make this statement.

2. THAT the aforesaid Bidder, its Directors and subcontractors have not been debarred from participating in procurement proceeding under Part IV of the Act.

3. THAT what is deponed to herein above is true to the best of my knowledge, information and belief.

..... (Title) (Signature) (Date)

Bidder Official Stamp

[October 2024]

**FORM SD 2: SELF DECLARATION THAT THE TENDERER WILL NOT ENGAGE IN ANY CORRUPT OR FRAUDULENT PRACTICE**

I, .....of P. O. Box.....being a resident of .....in the Republic of.....do hereby make a statement as follows:

- 1. THAT I am the Chief Executive/Managing Director/Principal Officer/Director of..... (insert name of the Company) who is a Bidder in respect of Tender No. .... for ..... (*insert tender title/description*) for ..... (*insert name of the Procuring entity*) and duly authorized and competent to make this statement.
- 2. THAT the aforesaid Bidder, its servants and/or agents /subcontractors will not engage in any corrupt or fraudulent practice and has not been requested to pay any inducement to any member of the Board, Management, Staff and/or employees and/or agents of ..... (*insert name of the Procuring entity*) which is the procuring entity.
- 3. THAT the aforesaid Bidder, its servants and/or agents /subcontractors have not offered any inducement to any member of the Board, Management, Staff and/or employees and/or agents of..... (*name of the procuring entity*).
- 4. THAT the aforesaid Bidder will not engage/has not engaged in any corrosive practice with other bidders participating in the subject tender
- 5. THAT what is deponed to herein above is true to the best of my knowledge information and belief.

.....  
 .....  
 (Title) (Signature) (Date)

Bidder's Official Stamp

[October 2024]

**FORM SD 3: DECLARATION AND COMMITMENT TO THE CODE OF ETHICS**

I,..... (Person) on behalf of (Name of the Business/Company/Firm) .....declare that I have read and fully understood the contents of the Public Procurement & Asset Disposal Act, 2015, Regulations and the Code of Ethics for persons participating in Public Procurement and Asset Disposal and my responsibilities under the Code.

I do hereby commit to abide by the provisions of the Code of Ethics for persons participating in Public Procurement and Asset Disposal.

Name of Authorized signatory.....

Sign.....

Position.....

Office address.....Telephone.....

E-mail.....

Name of the Firm/Company.....

Date.....

*(Company Seal/ Rubber Stamp where applicable)*

Witness Name.....

Sign.....

Date.....



[October 2024]

**APPENDIX 1-FRAUD AND CORRUPTION***(Appendix 1 shall not be modified)***1. Purpose**

The government of Kenya's Anti-Corruption and Economic Crime laws and their sanction's policies and procedures, Public Procurement and Asset Disposal Act (*no. 33 of 2015*) and its Regulation, and any other Kenya's Acts or Regulations related to Fraud and Corruption, and similar offences, shall apply with respect to Public Procurement Processes and Contracts that are governed by the laws of Kenya.

**2. Requirements**

The Government of Kenya requires that all parties including Procuring Entities, Tenderers, (applicants/proposers), Contractors, Contractors and Suppliers; any Sub-contractors, Service providers or Suppliers; any Agents (whether declared or not); and any of their Personnel, involved and engaged in procurement under Kenya's Laws and Regulation, observe the highest standard of ethics during the procurement process, selection and contract execution of all contracts ,and refrain from Fraud and Corruption and fully comply with Kenya's laws and Regulations as per paragraphs 1.1 above.

Kenya's public procurement and asset disposal act (*no.33 of 2015*) under Section 66 describes rules to be followed and actions to be taken in dealing with Corrupt, Coercive, Obstructive, Collusive or Fraudulent practices, and Conflicts of Interest in procurement including consequences for offences committed. A few of the provisions noted below highlight Kenya's policy of no tolerance for such practices and behavior:

- (1) a person to whom this Act applies shall not be involved in any corrupt, coercive, obstructive, collusive or fraudulent practice; or conflicts of interest in any procurement or asset disposal proceeding
- (2) A person referred to under sub section (1) who contravenes the provisions of that sub-section commits an offence
- (3) Without limiting the generality of the subsection (1) and (2), the person shall be: -
  - a) disqualified from entering into a contract for a procurement or asset disposal proceeding; or
  - b) if a contract has already been entered into with the person, the contract shall be avoidable
- (4) The voiding of a contract by the procuring entity under subsection (7) does not limit any legal remedy the procuring entity may have

[October 2024]

- (5) An employee or agent of the procuring entity or a member of the Board or committee of the procuring entity who has a conflict of interest with respect to a procurement—
  - i) Shall not take part in the procurement proceedings
  - ii) shall not, after a procurement contract has been entered into, take part in any decision relating to the procurement or contract; and
  - iii) Shall not be a sub-contractor for the tender to whom was awarded contract, or a member of the group of tenderers to whom the contract was awarded, but the sub-contractor appointed shall meet all the requirements of this Act.
- (6) An employee, agent or member described in subsection (1) who refrains from doing anything prohibited under that subsection, but for that subsection, would have been within his or her duties shall disclose the conflict of interest to the procuring entity
- (7) If a person contravenes sub section (1) with respect to a conflict of interest described in subsection (5)(a) and the contract is awarded to the person or his relative or to another person in whom one of them had a direct or indirect pecuniary interest, the contract shall be terminated and all costs incurred by the public entity shall be made good by the awarding officer.
- (8) Incompliance with Kenya's laws, regulations and policies mentioned above, the Procuring Entity:
  - a) Defines broadly, for the purposes of the above provisions, the terms set forth below as follows:
    - i) “Corrupt practice” is the offering, giving, receiving, or soliciting, directly or indirectly, of anything of value to influence improperly the actions of another party
    - ii) “Fraudulent practice” is any act or omission, including misrepresentation, that knowingly or  
  
Recklessly misleads, or attempts to mislead, a party to obtain financial or other benefit or to avoid an obligation
    - iii) “Collusive practice “is an arrangement between two or more parties designed to achieve an improper purpose, including to influence improperly the actions of another party
    - iv) “Coercive practice” is impairing or harming, or threatening to impair or harm, directly or indirectly, any party or the property of the party to influence improperly the actions of a party

[October 2024]

v) “Obstructive practice” is:

- i) deliberately destroying, falsifying, altering, or concealing of evidence material to the investigation or making false statements to investigators in order to materially impede investigation by Public Procurement Regulatory Authority (PPRA) or any other appropriate authority appointed by Government of Kenya into allegations of a corrupt, fraudulent, coercive, or collusive practice; and/or threatening, harassing, or intimidating any party to prevent it from disclosing its knowledge of matters relevant to the investigation or from pursuing the investigation; or
- ii) Acts intended to materially impede the exercise of the PPRA’s, or the appointed authority's inspection and audit rights provided for under paragraph 2.3e. Below.

b) Defines more specifically, in accordance with the above procurement Act provisions set forth for fraudulent and collusive practices as follows:

"Fraudulent practice" includes a misrepresentation of fact in order to influence a procurement or disposal process or the exercise of a contract to the detriment of the procuring entity or the tenderer or the contractor and includes collusive practices amongst tenderers prior to or after tender submission designed to establish tender prices at artificial non-competitive levels and to deprive the procuring entity of the benefits of free and open competition.

- c) Rejects a proposal or award of a contract if PPRA determines that the firm or individual recommended for award, any of its personnel, or its agents, or its sub-Contractors, sub-contractors, service providers, suppliers and/ or their employees, has, directly or indirectly, engaged in corrupt, fraudulent, collusive, coercive, or obstructive practices in competing for the contract in question
- d) Pursuant to the Kenya's above stated Acts and Regulations, may sanction or debar or recommend to appropriate authority (ies) for sanctioning and debarment of a firm or individual, as applicable under the Acts and Regulations
- e) Requires that a clause be included in Tender documents and Request for Proposal documents requiring (i) Tenderers (applicants/proposers), Contractors, Contractors, and Suppliers and their Sub-contractors, Sub- Contractors, Service providers, Suppliers, Agents personnel, permit the PPRA or any other appropriate authority appointed by Government of Kenya to inspect<sup>2</sup>all accounts, records and other documents relating to

[October 2024]

the procurement process, selection and/or contract execution, and to have them audited by auditors appointed by the PPRA or any other appropriate authority appointed by Government of Kenya; and

- f) Pursuant to Section 62 of the above Act, requires Applicants/Tenderers to submit along with their Applications/Tenders/Proposals a “Self-Declaration Form” as included in the procurement document declaring that they and all parties involved in the procurement process and contract execution have not engaged/will not engage in any corrupt or fraudulent practices.

*<sup>1</sup>For the avoidance of doubt, a party's ineligibility to be awarded a contract shall include, without limitation,*

*(i) applying for pre-qualification, expressing interest in*

*A consultancy, and tendering, either directly or as a nominated sub-contractor, nominated Contractor, nominated manufacturer or supplier, or nominated service provider, in respect of such contract, and(ii) entering into an addendum or amendment introducing a material modification to any existing contract.*

*<sup>2</sup> Inspections in this context usually are investigative (i.e., forensic) in nature. They involve fact-finding activities undertaken by the Investigating Authority or persons appointed by the Procuring Entity to address specific matters related to investigations/audits, such as evaluating the veracity of an allegation of possible Fraud and Corruption, through the appropriate mechanisms. Such activity includes but is not limited to: accessing and examining a firm's or individual's financial records and information, and making copies thereof as relevant; accessing and examining any other documents, data and information (whether in hard copy or electronic format) deemed relevant for the investigation/audit, and making copies thereof as relevant; interviewing staff and other relevant individuals; performing physical inspections and site visits; and obtaining third party verification of information.*

[October 2024]

**FORM TECH-6: CONTRACTOR'S ORGANIZATION AND EXPERIENCE**

A brief description of the Contractor's organization and an outline of the recent experience of the Contractor that is most relevant to the assignment. For each assignment, the outline should indicate the names of the Contractor's Key Staff and Sub-Contractors who participated, the duration of the assignment, the contract amount (total and, if it was done in a form of a joint venture or a sub-consultancy, the amount paid to the Contractor), and the Contractor's role/involvement.

**A - Contractor's Organization**

Provide here a brief description of the background and organization of your company.

**B - Contractor's Experience**

- List only previous similar assignments successfully completed in the last 5 years. (Attach previous completion certificates if any).
- List only those assignments for which the Contractor was legally contracted by the Procuring Entity as a company. Assignments completed by the Contractor's individual experts working privately or through other firms cannot be claimed as the relevant experience of the Contractor, or that of the Contractor's partners or sub-Contractors, but can be claimed by the Experts themselves in their Curriculum Vitae (CV).
- The Contractor shall substantiate their claimed experience by presenting copies of relevant documents such as the form of contract (not the whole contract), purchase order, service order, performance certificate, Final Certificate of Completion, etc.; which shall be included in the proposal as part of *Form Tech 13 Mandatory Documentary Evidence*.

Assignment Name:		Country
Location within Country:		Staff provided by Your Firm/Entity(profiles):
Name of Client:		No. of Staff:
Address:		No of Staff-Months; Duration of Assignment:
Start Date (Month/Year):	Completion Date (Month/Year):	Approx. Value of Services (KSh):
Name of Senior Staff Involved and Functions Performed:		
Narrative Description of project:		
Description of Actual Services Provided by Your Staff:		

Firm's Name: \_\_\_\_\_

Name and title of signatory: \_\_\_\_\_

**\*\*You may reproduce for other projects for which your firm has been engaged.**

[October 2024]

## **FORM TECH-7: COMMENTS AND SUGGESTIONS**

Form TECH-7: The Contractor to provide comments and suggestions on the Terms of Reference, counterpart staff and facilities to be provided by the Procuring Entity that could improve the quality/effectiveness of the assignment; and on requirements for counterpart staff and facilities, which are provided by the Procuring Entity, including: administrative support, office space, local transportation, equipment, data, etc.

### **A - On the Terms of Reference**

*{Improvements to the Terms of Reference, if any}*

### **B - On Counterpart Staff and Facilities**

*{Include comments on counterpart staff and facilities to be provided by the Procuring Entity. For example, administrative support, office space, local transportation, equipment, data, background reports, etc., if any}*

[October 2024]

**FORM TECH-8: DESCRIPTION OF APPROACH, METHODOLOGY AND WORK PLAN**

*Bidders to provide their detailed methodology, work plan and Detailed Staffing Plan for the Assignment.*

[October 2024]

**FORM TECH-9: WORK SCHEDULE**

**Operations Management Activities**

*[M0, M1, M3 are months from the start of assignment)*

	M1	M2	M3	M4	.... Mn	M(n+1)	M(n+2)	M(n+3)
Activity (Work)								
_____								
_____								
_____								
_____								



[October 2024]

**FORM TECH-10: FINANCIAL SITUATION AND PERFORMANCE****PART 1**

Tenderer's Name: \_\_\_\_\_

Date \_\_\_\_\_ JV Member's Name \_\_\_\_\_

ITT No. and title \_\_\_\_\_

**1. Financial data**

Type of Financial information (Kenya Shillings)	Historic information for previous _____ years,		
	(amount in Millions (KSh.))		
	2021	2022	2023
Statement of Financial Position (Information from Balance Sheet)			
Total Assets (TA)			
Total Liabilities (TL)			
Total Equity/Net Worth (NW)			
Current Assets (CA)			
Current Liabilities (CL)			
Working Capital (WC)			
Information from Income Statement			
Total Revenue (TR)			
Profits Before Taxes (PBT)			
Cash Flow Information			
Cash Flow from Operating Activities			

**2. Sources of Finance**

Specify sources of finance to meet the cash flow requirements on works currently in progress and for future contract commitments.

No.	Source of finance	Amount (Kenya Shilling equivalent)
1	Letter of Line of Credit from a recognized Financial Institution	
2	Bank account balance (demonstrated by bank statements for the last six (6) months)	

[October 2024]

### **3. Financial documents**

The Tenderer and its parties shall provide copies of financial statements for the last *three (3)* years pursuant Section III, Evaluation and Qualifications Criteria, Sub-factor 3.1. The financial statements shall:

- a) Reflect the financial situation of the Tenderer or in case of JV member, and not an affiliated entity (such as parent company or group member).
- b) Be independently audited or certified in accordance with local legislation.
- c) Be complete, including all notes to the financial statements.
- d) Correspond to accounting periods already completed and audited.

Attached are copies of financial statements for the three (3) years required above; and complying with the requirements

[October 2024]

**PART 2****Detailed Financial Situation Evaluation**

No.	Description	Auditors Assessment 2021	Auditors Assessment 2022	Auditors Assessment 2023	Evaluation Score Award Criteria
1	Financial Ratios				Max Score is= 4 Marks
a.	<b>Current Ratio=</b> <b><u>Current Assets</u></b> <b>Current Liabilities</b>				Current Ratio more than 1 = 1 marks
b.	<b>Debt to Equity Ratio =</b> <b><u>Total Liabilities</u></b> <b>Total Equity</b>				Equity Capital Ratio less than 1 = 1 Marks
c.	<b>Working Capital =</b> <b>Current Assets-Current</b> <b>Liabilities</b>				Positive Working Capital = 1 marks
d.	<b>Operating Cash Flow Ratio</b> = <b><u>Cash Flow from</u></b> <b><u>Operations</u></b> <b>Current Liabilities</b>				Operating Cash-flow more than 1 = 1 marks
2.	<b>Average Annual Working Capital in Ksh. ....</b>				Average Annual Working Capital is equal or more than KSh 100,000,000.00  = 0 or 6 Marks

The above Financial Ratios have to be derived from first Principles from the Audit Statements. The Auditor who has undertaken the analysis has to demonstrate the financial ratios and append his signature and stamp to the Document as below:

The Auditor shall be required to provide his/her workings and demonstrate the source of the workings from the various Audited statements by including the Page Numbers and references of the source of the figures used in the computation of the assigned values.

**The Auditor undertaking the above Financial Analysis MUST duly fill the Contact Sheet below in all aspects and attach current annual practising license.**

[October 2024]

**Financial ratios Computed by a Certified Public Accountant:**

<b>CPA: Name</b>	
<b>ICPAK Number</b>	
<b>Telephone Number</b>	
<b>Email Address</b>	
<b>Postal Address</b>	
<b>Physical Address</b>	
<b>Contact Person</b>	
<b>Mobile Contact of the Contact Person</b>	
<b>Signature</b>	
<b>Date</b>	
<b>Personal/Corporate Stamp</b>	

**Ratios attested by the Company Director:**

<b>Director's Name</b>	
<b>ID/Passport Number</b>	
<b>Telephone Number</b>	
<b>Email Address</b>	
<b>Postal Address</b>	
<b>Physical Address</b>	
<b>Signature</b>	
<b>Date</b>	
<b>Personal/Corporate Stamp</b>	

[October 2024]

**FORM TECH – 11: AVERAGE ANNUAL TURNOVER**

Tenderer's Name: \_\_\_\_\_

Date: \_\_\_\_\_

JV Member's Name \_\_\_\_\_

ITT No. and title: \_\_\_\_\_

<b>Annual similar services turnover data</b>			
<b>Year</b>	<b>Amount Currency</b> <i>[insert amount and indicate currency]</i>	<b>Exchange Rate</b> <b>(where applicable)</b>	<b>Kenya Shilling equivalent</b>
2021			
2022			
2023			
<b>Average Annual Similar Services Turnover*</b>			

\* See Section III, Evaluation and Qualification Criteria.

*If the most recent set of financial statements is for a period earlier than 12 months from the date of Bid, the reason for this should be justified.*

[October 2024]

**FORM TECH 12: CURRENT CONTRACT COMMITMENTS / WORKS IN PROGRESS**

Tenderers and each member to a JV should provide information on their current commitments on all contracts that have been awarded, or for which a Form of intent or acceptance has been received, or for contracts approaching completion, but for which an unqualified, full completion certificate has yet to be issued.

<b>Current Contract Commitments</b>					
No.	Name of Contract	Procuring Entity's Contact Address, Tel, Fax	Value of Outstanding Work (Kenya Shilling equivalent)	Estimated Completion Date	Average Monthly Invoicing Over Last Six Months [KSh./month]
1					
2					
3					
4					
5					

[October 2024]

## **SCHEDULE A: SUB-CONTRACTORS / PARTNERS**

Tenderers shall list below those parts of the Works and Services which they propose to subcontract and state the approximate value of those parts and the names and addresses of the proposed subcontractors, if those are known at Tendering stage. Tenderers shall also list other business partners involved in the execution of the contract and their respective roles and responsibilities.

Part of Works /  
Services:

Approximate value:

Name and address of proposed subcontractor / partner:

Part of Works /

Services: Approximate  
value:

Name and address of proposed subcontractor / partner:

Part of Works /

Services: Approximate  
value:

Name and address of proposed subcontractor / partner:

Part of Works /

Services: Approximate  
value:

Name and address of proposed subcontractor / partner:

[October 2024]

**FORM EQU: CONTRACTOR'S EQUIPMENT**

The Tenderer shall provide adequate information to demonstrate clearly that it has the capability to perform the contract. A separate Form shall be prepared for each item of equipment listed, or for alternative equipment proposed by the Tenderer.

<b>Item of equipment</b>		
Equipment information	Name of manufacturer	Model and power rating
	Capacity	Year of manufacture
Current Status	Current Location	
	Details of current commitments	
Source	Indicate source of equipment <input type="checkbox"/> Owned <input type="checkbox"/> Rented <input type="checkbox"/> Leased <input type="checkbox"/> Specially manufactured	

Omit the following information for equipment owned by the Tenderer.

Owner	Name of owner	
	Address of owner	
	Telephone	Contact name and title
	Fax	
Agreements	Details of rental/ lease/ manufacture agreements specific to the project	



[October 2024]

**FORM PER -1: KEY PERSONNEL SCHEDULE**

Tenderers should provide the names and details of the suitably qualified Key Personnel to perform the Contract. The data on their experience should be supplied using the Form PER-2 below for each candidate.

**Key Personnel**

<b>1.</b>	<b>Title of position: Operations Manager</b>	
	<b>Name of candidate:</b>	
	<b>Duration of appointment:</b>	<i>[insert the whole period (start and end dates) for which this position will be engaged]</i>
	<b>Time commitment for this position:</b>	<i>[insert the number of days/weeks/months that has been scheduled for this position]</i>
	<b>Expected time schedule for this position:</b>	<b><i>Full time site presence</i></b>
<b>2.</b>	<b>Title of position: ...</b>	
	<b>Name of candidate:</b>	
	<b>Duration of appointment:</b>	<i>[insert the whole period (start and end dates) for which this position will be engaged]</i>
	<b>Time commitment for this position:</b>	<i>[insert the number of days/weeks/months that has been scheduled for this position]</i>
	<b>Expected time schedule for this position:</b>	<b><i>Full time site presence</i></b>

Countersignature of authorized representative of the Tenderer:

Signature: \_\_\_\_\_

Date: (day month year): \_\_\_\_\_

[October 2024]

**Form PER -2****Resume and Declaration – Key Personnel**

<b>Name of Tenderer</b>
-------------------------

<b>Position [1]: [title of position from Form PER-1]</b>		
<b>Personnel information</b>	<b>Name:</b>	<b>Date of birth:</b>
	<b>Address:</b>	<b>E-mail:</b>
	<b>Professional qualifications:</b>	
	<b>Academic qualifications:</b>	
	<b>Language proficiency: [language and levels of speaking, reading and writing skills]</b>	
<b>Details</b>	<b>Address of Bidding Firm:</b>	
	<b>Telephone:</b>	<b>Contact (manager/personnel officer):</b>
	<b>Fax:</b>	
	<b>Job title:</b>	<b>Years with present Bidding Firm:</b>

Summarize professional experience in reverse chronological order. Indicate particular technical and managerial experience relevant to the project.

<b>Project</b>	<b>Role</b>	<b>Duration of involvement</b>	<b>Relevant experience</b>
<i>[main project details]</i>	<i>[role and responsibilities on the project]</i>	<i>[time in role]</i>	<i>[describe the experience relevant to this position]</i>

**Declaration**

I, the undersigned Key Personnel, certify that to the best of my knowledge and belief, the information contained in this Form PER -2 correctly describes myself, my qualifications and my experience.

I confirm that I am available as certified in the following table and throughout the expected time schedule for this position as provided in the Tender:

<b>Commitment</b>	<b>Details</b>
Commitment to duration of contract:	<i>[insert period (start and end dates) for which this Key Personnel is available to work on this contract]</i>
Time commitment:	<i>[insert the number of days/weeks/months that this Key Personnel will be engaged]</i>

I understand that any misrepresentation or omission in this Form may:

- be taken into consideration during Tender evaluation;
- my disqualification from participating in the Tender;
- my dismissal from the contract.

Name of Key Personnel: *[insert name]*

Signature: \_\_\_\_\_

[October 2024]

Date: (day month year): \_\_\_\_\_

Countersignature of authorized representative of the Tenderer:

Signature: \_\_\_\_\_

Date: (day month year): \_\_\_\_\_

[October 2024]

**FORM Per 3: CURRICULUM VITAE (CV)**

<b>Position Title and No.</b>	(e.g., K-1, Team leader)
<b>Name Of Staff</b>	(Insert full name)
<b>Date Of Birth</b>	(day/month/year)
<b>Country of Citizenship</b>	

**Education:** {List college/university or other specialized education, giving names of educational institutions, dates attended, degree(s)/diploma(s) obtained}

---

Employment record relevant to the assignment: {Starting with present position, list in reverse order. Please provide dates, name of employing organization, titles of positions held, types of activities performed and location of the assignment, and contact information of previous Procuring Entity's and employing organization(s) who can be contacted for references. Past employment that is not relevant to the assignment does not need to be included.}

S. No	Period	Employing Organization and your title/position. Contact in form for reference.	Country	Summary of activities performed relevant to the assignment
1.	(e.g, May.2021- Present)	Organisation:  Reference:		
2.	(e.g, May.2021- Present)	Organisation:  Reference:		

Membership in Professional Associations and Publications: \_\_\_\_\_

Language Skills (indicate only languages in which you can work): \_\_\_\_\_

---

[October 2024]

Adequacy for the Assignment:

Detailed Task Assigned on Contractor’s Team Expert	Reference to prior work/assignments that best illustrates capacity to handle the assigned task
<i>[list all deliverables/tasks which the Expert will be involved]</i>	

Expert's contact information

E-mail: .....

Phone: .....

Certification:

I, the undersigned, certify that to the best of my knowledge and belief, this CV correctly describes myself, my qualifications, and my experience, and I am available to undertake the assignment in case of an award. I understand that any misstatement or misrepresentation described herein may lead to my disqualification or dismissal by the Procuring Entity, and/or sanctions by the PPRA.

{Day / month/year}

Name of Expert \_\_\_\_\_ Signature \_\_\_\_\_ Date \_\_\_\_\_

{Day / month/year}

Name of authorized \_\_\_\_\_ Signature \_\_\_\_\_ Date \_\_\_\_\_

Representative of the  
Contractor (the same who  
signs the Proposal

## **FORMTECH-13: MANDATORY SUPPORT DOCUMENTS**

*[The Contractor shall use this form to submit all the required support documentary evidence as required in the RFP, especially the following mandatory and eligibility criteria]*

- a) Certificate of Incorporation/Certificate of Registration

*{Insert here a copy of certificate of incorporation or registration}*

- b) Tax Compliance Certificate

*{Contractor to insert a copy of the tax compliance certificate from Kenya Revenue Authority or similar body in the case of foreign consulting firms}*

- c) Similar Assignments Experience

*{Contractor to insert here copies of the form of contract, purchase order, service order, and performance certificate or similar evidence of similar assignments carried out by the firm. The assignments shall be the same as those provided under FORM TECH 6}*

- d) Current workload

- e) Litigation history (**Current** sworn affidavit) within the last three (3) months.

- f) Academic Certificates

*{Contractor to insert copies of the required relevant academic certificates relevant to the assignment for all the Key Staff}*

- g) Professional Certificates

*{Contractor to insert copies of professional certificates and relevant short-term trainings to demonstrate professional qualifications for all the Key Staff}*

- h) Professional Membership of Key Staff

*{If applicable, Contractor to insert copies of professional membership certificate for its Key Staff}*

- i) Certificate of Independent Proposal Determination

*(The Form is available on Tech FORM TECH-1: TECHNICAL PROPOSAL SUBMISSION FORM).*

[October 2024]

**FORM TECH – 14: FORM OF TENDER SECURITY - Form of Demand Guarantee**  
**Beneficiary** \_\_\_\_\_

**Invitation to Tender No:** \_\_\_\_\_

**Date:** \_\_\_\_\_ **TENDER GUARANTEE No.:** \_\_\_\_\_

**Guarantor:** \_\_\_\_\_

We have been informed that \_\_\_\_\_ (herein after called "the Applicant") has submitted or will submit to the Beneficiary its Tender (herein after called "the Tender") for the execution of **MANAGEMENT, OPERATION AND MAINTENANCE OF WEBUYE WEIGHBRIDGE STATION AND THE 2073 KM ADJACENT ROAD NETWORK** under Invitation to Tender No. \_\_\_\_\_

Furthermore, we understand that, according to the Beneficiary's conditions, Tenders must be supported by a Tender guarantee.

At the request of the Applicant, we, as Guarantor, hereby irrevocably undertake to pay the Beneficiary any sum or sums not exceeding in total an amount of **KSh 750,000.00** upon receipt by us of the Beneficiary's complying demand, supported by the Beneficiary's statement, whether in the demand itself or a separate signed document accompanying or identifying the demand, stating that either the Applicant:

- a) has withdrawn its Tender during the period of tender validity set forth in the Applicant's Form of Tender ("the Tender Validity Period"), or any extension thereto provided by the Applicant; or
- b) having been notified of the acceptance of its Tender by the Beneficiary during the Tender Validity Period or any extension thereto provided by the Applicant, (i) has failed to execute the contract agreement, or (ii) has failed to furnish the performance security, in accordance with the Instructions to Tenderers ("ITT") of the Beneficiary's Tendering Document.

This guarantee will expire: (a) if the Applicant is the successful Tenderer, upon our receipt of copies of the contract agreement signed by the Applicant and the performance security issued to the Beneficiary in relation to such contract agreement; or (b) if the Applicant is not the successful Tenderer, upon the earlier of (i) our receipt of a copy of the Beneficiary's notification to the Applicant of the results of the Tendering process; or (ii) twenty-eight days after the end of the Tender Validity Period.

Consequently, any demand for payment under this guarantee must be received by us at the office indicated above on or before that date.

\_\_\_\_\_  
[Signature]

*Note: All italicized text is for use in preparing this form and shall be deleted from the final product.*

[October 2024]

**FORM TECH - 15: TENDER-SECURING DECLARATION FORM**

[The Bidder shall complete this Form in accordance with the instructions indicated]

Date: ..... [Insert date (as day, month and year) of Tender Submission]

Tender No: ..... [Insert number of tendering process]

To: ..... [Insert complete name of Purchaser]

I/We, the undersigned, declare that:

1. I / We understand that, according to your conditions, bids must be supported by a Tender-Securing Declaration.
2. I /We accept that I/we will automatically be suspended from being eligible for tendering in any contract with the Purchaser or the period of time of [N/A] starting on[N/A], if we are in breach of our obligation (s)under the bid conditions, because we–(a) have withdrawn our tender during the period of tender validity specified by us in the Tendering Data Sheet; or (b) having been notified of the acceptance of our Bid by the Purchaser during the period of bid validity,(i) fail or refuse to execute the Contract, if required, or (ii) fail or refuse to furnish the Performance Security, in accordance with the instructions to tenders.
3. I / We understand that this Tender Securing Declaration shall expire if we are not the successful Tenderer (s), upon the earlier of:
  - a) Our receipt of a copy of your notification of the name of the successful Tenderer; or
  - b) Thirty days after the expiration of our Tender.
4. I/We understand that if I am /we are/in a Joint Venture, the Tender Securing Declaration must be in the name of the Joint Venture that submits the bid, and the Joint Venture has not been legally constituted at the time of bidding, the Tender Securing Declaration shall be in the names of all future partners as named in the letter of intent.

Signed:

.....

Capacity / title (director or partner or sole proprietor, etc.)

Name:.....

Duly authorized to sign the bid for and on behalf of: ..... [Insert complete name of Tenderer] Dated on ..... day of ..... [Insert date of signing]

Seal or stamp



[October 2024]

**FORM TECH – 16: FORM OF WRITTEN POWER OF ATTORNEY**

The Bidder shall state here below the name(s) and address of his representative(s) who is/are authorized to receive on his behalf correspondence in connection with the Bid.

.....  
(Name of Bidder’s Representative in block letters)

.....  
(Address of Bidder’s Representative)

.....  
(Signature of Bidder’s Representative)

Alternate:

.....  
(Name of Bidder’s Representative in block letters)

.....  
(Address of Bidder’s Representative)

.....  
(Signature of Bidder’s Representative)

\*To be filled by all Bidders.

[October 2024]

**FORM TECH – 17: HISTORICAL CONTRACT NON-PERFORMANCE, PENDING LITIGATION AND LITIGATION HISTORY**

Tenderer's Name: \_\_\_\_\_ Date: \_\_\_\_\_

JV Member's Name \_\_\_\_\_

ITT No. and title: \_\_\_\_\_

Non- Performed Contracts in accordance with Section III, Evaluation and Qualification Criteria			
<input type="checkbox"/> Contract non-performance did not occur for the last three (3) years from the day of tender opening. <input type="checkbox"/> Contract(s) not performed for the last three (3) years from the day of tender opening			
Year	Non-performed portion of contract	Contract Identification	Total Contract Amount (Kenya Shilling equivalent)
[insert year]	[insert amount and percentage]	Contract Identification: [indicate complete contract name/number; and any other identification] Name of Procuring Entity: [insert full name] Address of Procuring Entity: [insert street/city/country] Reason(s) for nonperformance: [indicate main reason(s)]	[insert amount]
Pending Litigation, in accordance with Section III, Qualification Criteria and Requirements			
<input type="checkbox"/> No pending litigation in accordance with Section III, Qualification Criteria and Requirements, Sub-Factor 8. <input type="checkbox"/> Pending Litigation in accordance with Section III, Evaluation and Qualification Criteria, Sub-Factor 9 as indicated below			
Year of dispute	Amount in dispute (currency)	Contract Identification	Total Contract Amount (Kenya Shilling equivalent)
		Contract Identification: _____ Name of Procuring Entity: _____ Address of Procuring Entity: _____ Matter in dispute: _____ Party who initiated the dispute: _____ Status of dispute: _____	
		Contract Identification: _____ Name of Procuring Entity: _____ Address of Procuring Entity: _____ Matter in dispute: _____ Party who initiated the dispute: _____ Status of dispute: _____	
Litigation History in accordance with Section III, Evaluation and Qualification Criteria			
<input type="checkbox"/> No Litigation History in accordance with Section III, Evaluation and Qualification Criteria, Sub-Factor 2.4. <input type="checkbox"/> Litigation History in accordance with Section III, Evaluation and Qualification Criteria, Sub-Factor 2.4 as indicated below			
Year of award	Outcome as percentage of Net Worth	Contract Identification	Total Contract Amount (Kenya Shilling equivalent)

[October 2024]

**FORM TECH – 18: DECLARATION FORM – FAIR EMPLOYMENT LAW AND PRACTICES**

Date

To

The Director General,  
Kenya National Highways Authority (KeNHA),  
P.O. Box 49712-00100

**NAIROBI**

We (name and address) \_\_\_\_\_

\_\_\_\_\_ declare the following:

1. Have not been involved in and will not be involved in violation of fair employment laws and practices.
2. THAT what is declared hereinabove is true to the best of my knowledge, information and belief

	.....	
Name of Bidder’s authorized Representative	Signature	Date

(To be signed by authorized representative and officially stamped)

**FORM TECH 19: DECLARATION OF KNOWLEDGE OF SITE**

This is to certify that

[Name/s].....

.....

Being the authorized representative/Agent of [Name of bidder]

.....

.....

Has familiarised himself/herself with the Site conditions in accordance with the Instructions to bidders and the Tender Notice for purposes of bidding for this project.

**MANAGEMENT, OPERATION AND MAINTENANCE OF WEBUYE WEIGHBRIDGE STATION AND THE 2073 KM ADJACENT ROAD NETWORK**

Having studied the tender Documents and gained knowledge of local conditions on site likely to influence the works and cost thereof, I certify that I am satisfied with the description of the works and understand the scope of works as specified and as implied in this tender.

.....

.....

(Signed and Stamped by Authorised Bidder’s Agent/ Representative)

(Designation)

[October 2024]

**PERFORMANCE BANK GUARANTEE**

To

Director General,  
Kenya National Highways Authority,  
P. O. Box 49712-00100,  
NAIROBI

WHEREAS ..... (Hereinafter called “the Contractor”) has undertaken in pursuance of Contract No ..... Dated ..... to execute the **MANAGEMENT, OPERATION AND MAINTENANCE OF WEBUYE WEIGHBRIDGE STATION AND THE 2073 KM ADJACENT ROAD NETWORK**, (hereinafter called the “Contract”)

**AND WHEREAS** it has been stipulated by you in the said Contract that the Contractor shall furnish you with a Bank Guarantee by a recognized bank for 5% of the sum tendered as security for compliance with his obligations in accordance with the Contract;

**AND WHEREAS** we have agreed to give the Contractor such a Bank Guarantee;

**NOW THEREFORE** we hereby affirm that we are the Guarantor and responsible to you on behalf of the Contractor, up to a total of

KSh..... (Amount in figures)

KSh..... (Amount in words)

And we undertake to pay you, upon your first written demand and without cavil or argument, any sum or sums within and up to the limits as aforesaid without your needing to prove or show grounds or reasons for the sum specified therein.

We hereby waive the necessity of you demanding the said debt from the Contractor before presenting us with the demand.

We further agree that no change or addition to or other modification of the terms of the Contract or of the Works to be performed thereunder or of any of the Contract Documents which may be made between you and the Contractor shall in any way release us from any liability under this Guarantee and we hereby waive notice of any such change, addition or modification

This Guarantee shall be valid until 28 days after issuing of the Taking Over Certificate.

**SIGNATURE AND SEAL OF BANK** .....

Name of Signatory.....

Name of bank.....

Address.....

Date .....

[October 2024]

**APPENDIX TO FORM OF BID**  
**(This appendix forms part of the bid)**

CONDITIONS OF CONTRACT	CLAUSE	AMOUNT
Bid Security (Bank Guarantee Only)		<b>KSh. 750,000.00</b> in the form of Unconditional Bank Guarantee
Amount of Performance Security (Unconditional Bank Guarantee)	10.1	5% of the Tender Sum in the form of Unconditional Bank Guarantee
Program to be submitted	14.1	Not later than 14 (Fourteen) days after issuance of Order to Commence
Cash flow estimate to be submitted	14.3	Not later than 14 (Fourteen) days after issuance of Order to Commence
Minimum amount of Third-Party Insurance	23.2	50,000,000.00
Period for commencement, from Engineer's Order to Commence	41.1	14 days
Time for Completion	43.1	28 (Twenty-eight) months
Amount of Liquidated Damages	47.1(b)	The Management Contractor shall be surcharged an amount equivalent to five times the applicable fine/or overload fee of the overload as prescribed in the Act if any vehicle is impounded with overload after passing a static weighbridge under his/her management.
Defects Liability period	49.1	N/A
Period of Contract Validity	60	From contract signing up to the date of settlement of the agreed final statement issued pursuant to clause 60.6 rendering the contractor's clause 60.7 on discharge by the employer effective
Limit of Retention Money	60.3	5% of Contract Price
Minimum amount of interim certificates	60.2	N/A (An interim certificate is to be submitted for every operational month)
Time within which payment to be made after Interim Payment Certificate signed by Engineer	60.10	90 days
Time within which payment to be made after Final Payment Certificate signed by Engineer	60.10	90 days
Payment of Monthly Salaries/allowances to Contractor's employees and allowances due to all officers seconded by the Employer to the assignment.	16.1	Monthly payments to be made on or before the last day of the month. Any delays shall attract a penalty of <b>KSh 100,000</b> per day for the period salaries/due allowances are delayed
Advance Payment	60.12	N/A
Appointer of Adjudicator	67.3	The Chartered Institute of Arbitrators (Kenya)
Notice to Employer and Engineer	68.2	<b>The Employer's address is:</b> The Director General, Kenya National Highways Authority (KeNHA), P.O. Box 49712 - 00100 NAIROBI <b>The Engineer's address is:</b> Director Maintenance, Kenya National Highways Authority (KeNHA), P.O. Box 49712 – 00100 NAIROBI

[October 2024]

CONDITIONS OF CONTRACT	CLAUSE	AMOUNT
Bidder's Contact Details		<p><b>Bidder's Name:</b> .....</p> <p><b>P.O. Box:</b> .....</p> <p><b>Tel. No:</b> .....</p> <p><b>Email:</b> .....</p>

**Signature of Tenderer**..... **Date** .....

[October 2024]

**ANNEX A: FACILITY IMPROVEMENT AND MAINTENANCE ITEMS**

<b>WEBUYE CLUSTER WEIGHBRIDGE UPGRADE 2025</b>		
<b>No</b>	<b>DESCRIPTION</b>	<b>PROPOSED TIME FOR EXECUTION IN MONTHS.</b>
<b>1</b>	Construction of Administration block on the Malaba bound side of Webuye Weighbridge Station.	12 months
<b>2</b>	Provision, Installation and Commissioning of a second Multideck scale on the Malaba bound side of Webuye Weighbridge Station.	6 months
<p><b>NOTES</b></p> <p>1. Facility improvement and maintenance is to be expended on instructed items in the list based on competitive procurement of goods, services or works and shall be payable under a prime cost (PC) sum as shall be certified by the Engineer</p> <p>2. Time for execution is time it will take for completion of works from the date of being instructed by the Engineer</p>		



[October 2024]

**ANNEX B****UNIT RATES FOR CIVIL WORKS AND DAYWORKS (THE ENGINEER MAY CHOOSE TO USE THESE RATES OR SOURCE FOR COMPETITIVE RATES PREVAILING AT THE TIME)***The cost of executing all the items must be inserted, for the purpose of use on instructed works.*

ITEM	DESCRIPTION	UNIT	RATE KSh.
1.1	Clear site by cutting grass and small shrubs to allow for working space as will be directed by the Engineer.	m <sup>2</sup>	
1.2	Provide, excavate for, lay, and fix to free-flowing condition 600mm pipe culverts inclusive of BRC 142 reinforced concrete class 20/20 surround.	M	
1.3	Excavate for, provide and construct Head walls to culverts in class 25/20 concrete inclusive of formwork.	M <sup>3</sup>	
1.4	Grading including mitre drains as instructed	m <sup>2</sup>	
1.5	Spoil material to be disposed by Contractor	m <sup>3</sup>	
1.6	Provide approved gravel material, transport, place, spread, water and compact to a minimum of 95% Maximum Dry Density (MDD) / AASHTO T180 to achieve a 150mm uniform compacted thickness of gravel course	m <sup>3</sup>	
1.7	Cut, trim, and clean the existing potholes and uneven edges of the pavement	m <sup>3</sup>	
1.8	Provide, place and compact well graded gravel base for repair to potholes.	m <sup>3</sup>	
1.9	Provide graded crushed stone (GCS) stabilised at 3% with cement and cure as instructed.	m <sup>3</sup>	
1.10	Provide cement for stabilizing gravel base at a rate to be determined on site by the Engineer inclusive of protection and curing thereof	Ton	
1.11	Provide and apply evenly prime coat of bituminous emulsion (medium curing) MC 30/MC 70 by means of a mechanical or hand distributor at the rate of 0.75 - 0.95 litres per meter square.	Litres	
1.12	Provide and apply evenly a layer of bitumen (medium curing) MC 3000 or pen grade 80/100 by means of a mechanical distributor complying with the requirements of BS 1707 at the rate of 1.0 - 1.20 litres per meter square.	Litres	
1.13	Provide, transport, lay and roll 14/20 pre-coated chippings at a uniform rate of 90 - 120 square meter per meter cubed as first seal coat	m <sup>3</sup>	
1.14	Provide brooms and other materials, and sweep the Pavement to clear loose materials before application of bituminous tack coat	m <sup>2</sup>	
1.15	Provide, transport, lay and roll on the bitumen 6/10 precoated stone chippings at a uniform rate of 90 - 120 square meter per meter cubed as second seal coat.	m <sup>3</sup>	
1.16	Provide hot rolled asphaltic concrete Type I for pothole and regulation layer.	M <sup>3</sup>	
1.17	Excavate holes to receive posts not exceeding 1500mm and spread material as will be directed by the Engineer.	No.	
1.18	Plastic fencing posts at 3000mm centres including straining posts which will be nailed or bolted onto chamfered joints and class 20/20 concrete surround into the holes.	No.	
1.19	Barbed wire 2 ply gauge 16 or of equal or approved including staples and stapling on to posts.	LM	
1.20	Provide sign board on gauge 14 mild steel plate welded onto 50 x 50 x 3mm square hollow sections frame, fixed to the ground.	ITEM	
1.21	Provide and apply 3 coats of water-based paint to internal walls	m <sup>2</sup>	

[October 2024]

1.22	Provide and apply 3 coats of water-based paints to external walls	m <sup>2</sup>	
<b><u>DAYWORKS – PLANT</u></b>			
<b>Plant hire rates must be inclusive of all operation and maintenance costs such as fuels, oils, grease, water, drivers, operators, supervision overheads and profits. Only time actually employed upon the works will be certified by the Engineer and thereafter paid for.</b>			
1.23	Concrete mixer of 0.2 – 0.4 cubic meter capacity	Hours	
1.24	Concrete poker vibrator	Hours	
1.25	Motor Grader CAT 140G or equivalent complete with scarifier	Hours	
1.26	Tipper Truck	Hours	
1.27	Vibrating Roller over 6-ton weight	Hours	
1.28	Self-propelled water tanker of capacity 10,000 litres	Hours	
1.29	Wheel Loader	Hours	
1.30	Excavator	Hours	
1.31	Vibrating Pedestrian Roller	Hours	
1.32	Tipper Truck of at least 7 Tonnes	Hours	
1.33	4-Wheel drive vehicle	Hours	
<b><u>DAYWORKS – LABOUR</u></b>			
<b>Labour hire rates must be inclusive of all incidental costs such as insurance cover, accommodation, travelling and other overheads. Only the time engaged upon actual work will be certified by the Engineer and thereafter paid for.</b>			
1.34	Skilled labour	Hours	
1.35	Unskilled labour	Hours	
<b><u>DAYWORKS – MATERIALS</u></b>			
<b>All materials to be provided are to comply with the specifications and rates inserted herein. The offer price must also be inclusive of transportation to site as directed by the Engineer.</b>			
1.36	Concrete class 20 (20)	m <sup>3</sup> .	
1.37	Precast concrete slabs 600x600x50mm laid on 100mm compacted gravel base on compacted subgrade	m <sup>2</sup>	
1.38	200mm natural stone dressed or machine cut	m <sup>2</sup>	
1.39	Mild steel bars of various diameters to be specified by Engineer	Kg	
1.40	High Yield steel bars of various diameters to be specified by Engineer	Kg	
1.41	Hardcore	Ton	
1.42	Approved quarry waste	Ton	
1.43	Provide and apply paint on existing facilities, first grade oil paint or similar inclusive of all labour, brushes and other materials of any colour as will be directed by the Engineer,	Litres	
1.44	Provide aggregate(Ballast), all sizes , various grading sizes (6-30mm)	Tonnes	
1.45	Provide quarry dust (0-6mm)	Tonnes	
1.46	Provide river washed building sand	Tonnes	
1.47	Concrete class 25 (20)	m <sup>3</sup> .	

^NB: Rate should be inserted for all items listed above, for use during the project implementation period, and as instructed by the Engineer.

[October 2024]

## ANNEX C

## MAINTENANCE SCHEDULE OF WEIGHBRIDGE EQUIPMENT

WEBUYE MAINTENANCE SCHEDULE OF WEIGHBRIDGE EQUIPMENT					
Weighbridge	Equipment	Quantity	Daily	Weekly	Quarterly
<b>STATIC WEIGHING SCALES</b>					
<b>Malaba-Bound</b>	Multideck Scale	1	√	√	√
	LSWIM SAW Scale	1	√	√	√
<b>Eldoret-Bound</b>	Multideck Scale	1	√	√	√
<b>MOBILE WEIGHING SCALES</b>					
<b>Webuye</b>	Haenni Mobile Scales	4	√	√	√
<b>HIGH SPEED WEIGH IN MOTION</b>					
<b>Malaba-Bound</b>	HSWIM System	1		√	√
<b>Eldoret-Bound</b>	HSWIM System	1		√	√
<b>SYSTEM CAMERAS</b>					
<b>Malaba-Bound</b>	ANPR Cameras (Multideck)	1	√	√	√
	Sideview Cameras (Multideck)	1	√	√	√
<b>Eldoret-Bound</b>	ANPR Cameras (Multideck)	1	√	√	√
	Sideview Cameras (Multideck)	1	√	√	√
<b>BOOM BOX</b>					
<b>Malaba-Bound</b>	Boom Box	1		√	√
<b>Eldoret-Bound</b>	Boom Box	2		√	√
<b>CCTV CAMERAS</b>					
<b>All Bounds</b>	Indoor Cameras (HIK Vision IP Cameras)	16	√	√	√
	Outdoor Cameras (HIK Vision IP Cameras)	16	√	√	√
	PTZ Cameras	2	√	√	√
<b>BIOMETRIC ACCESS SYSTEMS</b>					
<b>Malaba-Bound</b>	Biometric Access Systems	13	√	√	√
<b>Eldoret-Bound</b>	Biometric Access Systems	4	√	√	√
<b>GENERATORS</b>					
<b>Webuye</b>	MPMC Perkins Engine Generator; 100kVA; 3 Phase	1	√	√	√
<b>UNINTERRUPTIBLE POWER SUPPLY (UPS)</b>					
<b>Malaba-bound</b>	Socomec Masterys; 20kVA; 3 Phase	1	√	√	√
<b>Eldoret-Bound</b>	Socomec Masterys; 20kVA; 3 Phase	1	√	√	√
<b>NVR</b>					
<b>Malaba-Bound</b>	32 CH	1	√	√	√
<b>Eldoret-Bound</b>	32 CH	1	√	√	√

[October 2024]

<b>AIR CONDITIONERS</b>					
<b>Malaba-bound</b>	Gree Ceiling Cassette Air Conditioner 18,000 BTU	1	√	√	√
	VON High Wall Split Air Conditioner 18,000 BTU	5	√	√	√
<b>Eldoret-Bound</b>	Gree Ceiling Cassette Air Conditioner 18,000 BTU	2	√	√	√
	VON High Wall Split Air Conditioner 18,000 BTU	1	√	√	√
<b>FIRE EXTINGUISHERS</b>					
<b>Malaba-Bound</b>	9kg Form	1		√	√
	5Kg Carbon Dioxide	1		√	√
	9kg Dry powder	7		√	√
	Automatic	1		√	√
<b>Eldoret-Bound</b>	9kg Dry Powder	2		√	√
<b>TV DISPLAYS</b>					
<b>Webuye</b>	Samsung TV Displays 55'	2	√	√	√

[October 2024]

<b>FACILITY AND EQUIPMENT MAINTENANCE SCHEDULE FOR A WEIGHBRIDGE</b>						
<b>INSPECTIONS &amp; SERVICE PERIODS</b>						
<b>EQUIPMENT/PLAN T</b>	<b>SHIFT</b>	<b>DAILY</b>	<b>WEEKL Y</b>	<b>MONTHL Y</b>	<b>QUARTE RLY</b>	<b>YEARLY</b>
PAINT				Inspect		Paint
ROOF					Inspect	
SEPTIC TANK				Inspect	Empty	
RESERVOIR			Inspect		Clean	
CLEANING OF WATER TANKS			Inspect	Clean		
DOORS			Inspect		Service	
GATES			Inspect		Service	
WINDOWS		Clean	Inspect		Service	
SENSORS IN TANKS		Check			Service	
SERVICING OF FIRE EXTINGUISHERS		Check		Inspect	Service	
TRAFFIC LIGHTS		Check				
ROAD MARKINGS				Inspect		Paint
ROAD SIGNS			Inspect			Service
TAPS INSIDE			Check			
TAPS OUTSIDE			Check			
TOILETS		Clean				
LIGHTS INSIDE			Check & Replace			
LIGHTS OUTSIDE			Check & Replace			
SCREENING SCALES	Inspect	Check	Clean		Service / Calibrate	
STATIC SCALES	Inspect & Internal Calibrati on	Cleanin g			Service / Calibrate	
COMPUTERS & PRINTERS		Check	Clean			
GRASS & COMPOUND		Clean	Trim Grass			Plant Trees

## **SECTION 4. FINANCIAL PROPOSAL - STANDARD FORMS**

*{Notes to Contractor shown in brackets {...} provide guidance to the Contractor to prepare the Financial Proposals; they should not appear on the Financial Proposals to be submitted.}*

Financial Proposal Standard Forms shall be used for the preparation of the Financial Proposal according to the instructions provided in Section 2.

FORM ELI- 1.3: 40% PERCENT RULE FORM

FORM OF BID

FIN-1 Financial Proposal Submission form

FIN-2 Summary of Costs

FIN-3 Breakdown of Price per Activity

FIN-4 Breakdown of remuneration per activity

[October 2024]

**FORM ELI- 1.3: 40% PERCENT RULE FORM**

Tenderers must complete this form to indicate they conform to the 40% Rule, i.e. 40% of their tender price is sourced from within Kenya.

ITEM	Description of Work Item	Describe location of source	Cost in Kenya shillings	Comments, if any
<b>A</b>	<b>Local Labour</b>			
1				
2				
3				
4				
5				
<b>B</b>	<b>Sub contracts from Local sources</b>			
1				
2				
3				
4				
5				
<b>C</b>	<b>Local materials</b>			
1				
2				
3				
4				
5				
<b>D</b>	<b>Use of Local Plant and Equipment</b>			
1				
2				
3				
4				
5				
<b>E</b>	<b>Add any other items</b>			

[October 2024]

1				
2				
3				
4				
5				
6				
7				
	TOTAL COST LOCAL CONTENT		xx	
	PERCENTAGE OF CONTRACT PRICE		xx	



[October 2024]

## FORM OF TENDER

### INSTRUCTIONS TO TENDERERS

- (i) The Tenderer must prepare this Form of Tender on stationery with its letterhead clearly showing the Tenderer's complete name and business address.
- (ii) All italicized text is to help Tenderer in preparing this form.
- (iii) Tenderer must complete and sign the TENDERER'S ELIGIBILITY- CONFIDENTIAL BUSINESS QUESTIONNAIRE, CERTIFICATE OF INDEPENDENT TENDER DETERMINATION and the SELF DECLARATION OF THE TENDERER, in the Technical Proposal.

### FORM OF TENDER

Date of this Tender submission: *[insert date (as day, month and year) of Tender submission]*

Invitation to Tender No.: *[insert identification]* Alternative No.: *[Not*

*Applicable]*

To: \_\_\_\_\_ We, \_\_\_\_\_ the undersigned, declare that:

- a) *No reservations:* We have examined and have no reservations to the tendering document, including Addenda issued in accordance with Instructions to Tenderers (ITT);
- b) *Eligibility:* We meet the eligibility requirements and have no conflict of interest in accordance with ITT4;
- c) *Tender-Securing Declaration:* We have not been suspended nor declared ineligible by the Procuring Entity based on execution of a Tender-Securing Declaration or Proposal-Securing Declaration in Kenya in accordance with ITT 4.8.
- d) *Conformity:* We offer to execute in conformity with the tendering document and in accordance with the construction or service schedule the following Works:  
*[Tender Number and Name]*
- e) *Tender Price:* The total price of our Tender is [name of currency] *(amount in figures and words)*.
- f) *Combined Price:* We hereby confirm that our combined price for Rehabilitation Works and Improvement Works does not exceed the threshold given in the TDS ITT 37.5, which is [insert percentage of the total contract price]. – Not Applicable
- g) *Tender Validity Period:* Our Tender shall be valid for a period specified in TDS 18.1 (or as amended if applicable) from the date fixed for the Tender submission deadline specified in TDS 22.1 (or as amended if applicable), and it shall remain binding upon us and may be accepted at any time before the expiration of that period;
- h) *Performance Security:* If our Tender is accepted, we commit to obtain a Performance Security in accordance with the tendering document;
- i) *One Tender per Tenderer:* We are not submitting any other Tender (s) as an individual Tenderer, and we are not participating in any other Tender(s) as a Joint Venture member or as a subcontractor, and meet the requirements of ITT 4.4, other than alternative Tenders submitted in accordance with ITT 13;
  - a) *Suspension and Debarment:* We, along with any of our subcontractors, suppliers, consultants, manufacturers, or service providers for any part of the contract, are not subject to, and not controlled by any entity or individual that is subject to, a temporary suspension or a debarment imposed by the Procuring Entity. Further, we are not ineligible under Kenya laws or official regulations or pursuant to a decision of the United Nations Security Council;
  - b) *State-owned enterprise or institution:* [select the appropriate option and delete the other] [We are not

[October 2024]

a state-owned enterprise or institution] / [We are a state-owned enterprise or institution but meet the requirements of ITT 4.7];

- c) *Commissions, gratuities and fees:* We have paid, or will pay the following commissions, gratuities, or fees with respect to the Tendering process or execution of the Contract: [insert complete name of each Recipient, its full address, the reason for which each commission or gratuity was paid and the amount and currency of each such commission or gratuity].

Name of Recipient	Address	Reason	Amount

(If none has been paid or is to be paid, indicate “none.”).

- d) *Binding Contract:* We understand that this Tender, together with your written acceptance thereof included in your Form of Acceptance, shall constitute a binding contract between us, until a formal contract is prepared and executed;
- e) *Not Bound to Accept:* We understand that you are not bound to accept the lowest evaluated cost Tender, the Best Evaluated Tender or any other Tender that you may receive;
- f) *Fraud and Corruption:* We hereby certify that we have taken steps to ensure that no person acting for us or on our behalf engages in any type of Fraud and Corruption;
  - g) *Collusive practices:* We hereby certify and confirm that the tender is genuine, non-collusive and made with the intention of accepting the contract if awarded. To this effect we have signed the “Certificate of Independent Tender Determination” attached below.
- r) We undertake to adhere by the Code of Ethics for Persons Participating in Public Procurement and Asset Disposal, copy available from \_\_\_\_\_ (specify website) during the procurement process and the execution of any resulting contract.
- s) We, the Tenderer, have completed fully and signed the following Forms as part of our Tender:
  - a) Tenderer's Eligibility; Confidential Business Questionnaire – to establish we are not in any conflict to interest.
  - b) Certificate of Independent Tender Determination – to declare that we completed the tender without colluding with other tenderers.
  - a) Self-Declaration of the Tenderer – to declare that we will, if awarded a contract, not engage in any form of fraud and corruption.
  - b) Declaration and commitment to the Code of Ethics for Persons Participating in Public Procurement and Asset Disposal.
- t) Further, we confirm that we have read and understood the full content and scope of fraud and corruption as informed in “Appendix 1- Fraud and Corruption” attached to the Form of Tender.

Name of the Tenderer: \*[insert complete name of person signing the Tender]

Name of the person duly authorized to sign the Tender on behalf of the Tenderer: \*\*[insert complete name of person duly authorized to sign the Tender]

Title of the person signing the Tender: [insert complete title of the person signing the Tender] Signature of the person named above: [insert signature of person whose name and capacity are shown above] Date signed [insert date of signing] day of [insert month], [insert year]

Name in the capacity of \_\_\_\_\_

Signed

Duly authorized to sign the Tender for and on behalf of

Dated on \_\_\_\_\_ day of \_\_\_\_\_, \_\_\_\_\_

[October 2024]

**FORM FIN-1: FINANCIAL PROPOSAL SUBMISSION FORM**

..... {Location, Date}

To: ..... [Name and address of Procuring Entity]

Dear Sirs:

We, the undersigned, offer to provide the consulting services for..... [Insert title of assignment] in accordance with your Request for Proposal dated..... [Insert Date] and our Technical Proposal.

Our attached Financial Proposal is for the amount of..... {Indicate the corresponding to the amount currency} {Insert amounts in words and figures}, including of all taxes in accordance with ITT28.2 in the Data Sheet. The estimated amount of local taxes is..... {Insert currency} {Insert amount in words and figures}.

{Please note that all amounts shall be the same as in Form FIN-2}.

Our Financial Proposal shall be valid and remain binding upon us, subject to the modifications resulting from Contract negotiations, for the period of time specified in the ITT13.1 Datasheet.

Commissions and gratuities paid or to be paid by us to an agent or any third party relating to preparation or submission of this Proposal and Contract execution, paid if we are awarded the Contract, are listed below:

Name and Address, Amount and Purpose of Commission of Agents, Currency or Gratuity

{If no payments are made or promised, add the following statement: “No commissions or gratuities have been or are to be paid by us to agents or any third party relating to this Proposal and Contract execution.”}

We understand you are not bound to accept any Proposal

you receive. We remain,

Yours sincerely,

Signature..... (Of Contractor's authorized representative) {In full and initials}

Full name: ..... {Insert full name of authorized representative}

Title: ..... {Insert title/position of authorized representative}

Name of Contractor..... (Company's name or JV's name)

Capacity: ..... {Insert the person's capacity to sign for the Contractor}

Physical Address: ..... {Insert the authorized representative's address}

Phone: ..... {Insert the authorized representative's phone and fax number, if applicable}

Email: ..... {Insert the authorized representative's email address}

{For a joint venture, either all members shall sign or only the lead member/Contractor, in which case the power of attorney to sign on behalf of all members shall be attached}

[October 2024]

**FORM FIN-2: SUMMARY OF COSTS**

<b>Costs</b>	<b>Amount(s) (KSh)</b>
<b>SUB TOTAL 1.</b>	
Add 2.5% of (Sub-Total I) as Contingencies	
<b>SUB TOTAL 2.</b>	
Add 16% VAT (of Sub-Total 2)	
Add 0.03% (of Sub-Total 2) Public Procurement Capacity Building Levy	
<b>SUB TOTAL 3.</b>	
<b>TOTAL AMOUNT (SUB TOTAL 3) OF FINANCIAL PROPOSAL</b>	

**FORM FIN-3: BREAKDOWN OF PRICE PER ACTIVITY****(a) Summary table**

<b>Price Component</b>	<b>Amount(s) KSh.</b>
Activity I. TRAFFIC AND MANAGEMENT	
Activity II. SECURITY AND ENFORCEMENT SERVICES	
Activity III. TRANSPORT COSTS	
Activity IV. OPERATIONAL COSTS	
Activity V. SUPERVISORY COSTS	
Activity VI. FACILITY IMPROVEMENT COSTS	
<b>SUB -TOTAL 1</b>	

[October 2024]

**FORM FIN-4: BREAKDOWN OF REMUNERATION PER ACTIVITY**

<b>MANAGEMENT OF WEBUYE WEIGHBRIDGE STATION AND 2073 KM ADJACENT NETWORK BREAKDOWN OF COSTS PER ACTIVITY</b>					
<b>ACTIVITY I: TRAFFIC AND MANAGEMENT</b>					
<b>Bidder to insert a rate for each item</b>					
<b>No</b>	<b>Description</b>	<b>Unit</b>	<b>Quantity</b>	<b>Rate (KSh)</b>	<b>Amount (KSh)</b>
1.1	Weighing and Issuance of weighbridge Certificates for diverted vehicles at the weighbridge station's static scales. This includes facilitation for arrest and prosecution (in courts) of overloaded vehicles, court attendant costs to provide evidence and overseeing load correction and issuance of Compliance Certificates.	No.	1,700,000		
1.2	Checking and Verification of Exemption Permits for Special Purpose Vehicles issued by KeNHA including verifying dimensions, axle and gross vehicle weights and vehicle roadworthiness. This includes facilitation for arrest and prosecution of vehicles which violates permit conditions and court attendant costs to provide evidence.	No.	26,000		
<b>TOTAL CARRIED FORWARD TO SUMMARY PAGE</b>					

[October 2024]

<b>ACTIVITY II: SECURITY AND ENFORCEMENT SERVICES</b>						
<b>Contractor to insert rate on Extra Over and rate for General security personnel. Amount + Quantity x Rate</b>						
<b>No</b>	<b>Description</b>	<b>Position</b>	<b>Unit</b>	<b>Quantity in Man Months</b>	<b>Rate per Month (KSh)</b>	<b>Amount (KSh)</b>
<b>POLICE OFFICERS</b>						
2.1	The Officer Commanding Station – Chief Inspector of Police		1	28	72,600.00	2,032,800.00
2.2	Deputy OCS - Inspector		1	28	57,800.00	1,618,400.00
2.3	Deputy OCS – Sergeant		3	84	46,900.00	3,939,600.00
2.4	Shift in charge - Corporals		12	336	46,900.00	15,758,400.00
2.5	Other Police Officers - Constables		23	644	37,800.00	24,343,200.00
<b>Sub Total 1</b>						<b>47,692,400.0</b>
2.6	Extra Over on Subtotal 1 for contractor's overheads and profits		%	47,692,400.0		
<b>Subtotal 2 = Subtotal 1+ Total of item 2.6</b>						
<b>TOTAL CARRIED FORWAR TO SUMMARY TABLE = Sub-Total 2</b>						

<b>ACTIVITY III: TRANSPORT COSTS</b>					
<b>No</b>	<b>Description</b>	<b>Unit</b>	<b>Quantity</b>	<b>Rate</b>	<b>Amount (KSh)</b>
3.1	Provide, fuel and maintain 2 No. Brand New 4 Wheel Drive Double cab pickup Vehicles of 2800cc - 3000cc engine capacity including driver, fuel and service for the exclusive use of the Engineer inclusive of the first 4,000km per vehicle month in accordance with clause 138 of Standard Specifications.	Vehicle months	56		
3.2	Extra over item 3.1 for mileage over 4,000km	km	112,000		
<b>TOTAL CARRIED FORWAR TO SUMMARY PAGE</b>					

[October 2024]

<b>ACTIVITY IV OPERATIONAL COSTS</b>					
<b>No</b>	<b>Item Description</b>	<b>unit</b>	<b>Quantity</b>	<b>Rate</b>	<b>Amount (KSh)</b>
4.1	Provisions for Reimbursement for Payment of Monthly Electricity Bills at Webuye Weighbridge station	PC Sum	1	5,000,000.00	5,000,000.00
4.2	E.O 4.1 for the contractor's overheads and profits	%	5,000,000.00		
4.3	Provide for Generator Power at Webuye Weighbridge station in the event of power outage. Genset running logs to be provided at each payment	Hours	2,000		
4.4	Remuneration of staff at the Cluster stations as detailed in the schedule attached in Appendix A	Months	28		
4.5	Operate and Maintain Webuye Weighbridge station on a continuous twenty-four-hour basis. Maintenance shall include all items contained in ANNEX C, telephones, use and replenishment of all consumables, Office Furniture, ICT Infrastructure, installed Computer & Servers Hardware and Software including licenses, Public Address and Public Display Systems, Maintenance of the compound and the office facilities (Including road reserve) through grass cutting to a maximum height of 50mm, bush clearing, opening of drains and culverts, general tidiness of the weighbridge station and watering of flowers beds.	Months	28		
4.6	Provide primary and secondary Internet Link with a capacity of 50MBPS with dedicated connectivity at Webuye Weighbridge Station. This shall include provision of a Wide Area network for all the sites within the cluster and KeNHA Headquarters. The redundant / secondary backup connectivity shall be from a separate internet service provider. One link shall be via fibre optic and the other one a wireless connection for continuous flow of data in case of fibre cut. The Primary and Secondary Internet Links shall be approved by the Engineer.	Months	28		
4.7.1	Prime Cost sum for maintenance and support of Weighbridge Management System that includes Updates, Upgrades and Annual Maintenance fee for a period of 28 Months.	PC sum	1	5,000,000.00	5,000,000.00
4.7.2	E.O 4.7.1 for the contractor's overheads and profits	%	5,000,000.00		
4.8.1	Provide for Quarterly Maintenance and calibration of weighing scales (Multidecks, HSWIM and Mobile (2No.)) at Webuye Weighbridge Station by Weights and Measures Department	Months	8		
4.8.2	Provide for calibration of Mobile Weighbridges for Headquarter Team and ALEHU Base Centres by Weights and Measures Department	No.	50		
4.8.3	Provide for ad-hoc or emergency Maintenance and calibration of one (1 No.) multideck scale at the weighbridge station as instructed by the Engineer	No.	28.00		

[October 2024]

4.9	Provision for Maintenance and Operation of 2 No. mobile weighbridge units across the Cluster Road network (2,073 Km) as per contract requirements. This includes facilitate for arrest and prosecution of vehicles with gross overload above 2 tonnes by mobile weighbridge units and attendant costs to provide evidence in courts.	Months	56		
4.10	PC Sum for Towing of abandoned, stalled or neglected vehicles during enforcement of Axle Load Control operations, information gathering and hiring of decoy vehicles to intercept overloaded vehicles	PC sum	1	10,000,000.00	10,000,000.00
4.11	E.O. 4.10 on PC sum for Towing of abandoned, stalled or neglected vehicles, information gathering and hiring of decoy vehicles to intercept overloaded vehicles for contractor's overheads and profits	%	10,000,000.00		
<b>TOTAL CARRIED FORWAR TO SUMMARY PAGE</b>					

**ACTIVITY V: SUPERVISORY COSTS**

	Item Description	Unit	Quantity	Unit Price (KSh)	Amount (KSh)
5.1	Payment of Engineers Supervisory Staff including overtime in accordance with clause 137 of the Standard Specifications and as per Remuneration Rates in Appendix B as instructed by the Engineer	Sum	1	30,047,450.00	30,047,450.00
5.2	Extra over item 5.1 for overheads and profits	%	30,047,450.00		
5.3	Payment of Resident Engineer Miscellaneous account as per clause 139 of Standard Specifications and for items and Services detailed in Appendix C	Sum	1		
5.4	Allow a prime cost sum of KSh 10,000,000 to be spent on reimbursements on Legal representation and travel costs for persons carrying out such work and attendance to court matters.	PC Sum	1	10,000,000.00	10,000,000.00
5.5	E.O. 5.4 on reimbursements on Legal representation and travel costs for Contractor's overheads and profits	%	10,000,000.00		
5.6	Periodic Stakeholders Meetings, Media Communication Sensitization and Coverage Cost reimbursements to be arranged in consultation with the Engineer	PC Sum	1	15,000,000.00	15,000,000.00
5.7	E.O 5.6 on Periodic Stakeholders Meetings, Media Communication and Coverage Costs reimbursements for Contractor's overheads and profits	%	15,000,000.00		
5.8	Provision for continuous engagement with the Courts through organized cluster retreats, CUCs, visits to individual Courts and other such facilitations	PC Sum	1	20,000,000.00	20,000,000.00
5.9	E.O 5.8 on for Contractor's overheads and profits	%	20,000,000.00		



[October 2024]

5.10	Provision for Annual Integrity Awareness Training of Weighbridge Staff by relevant internal and external bodies	PC Sum	1	6,000,000.00	6,000,000.00
5.11	E.O 5.10 on Annual Integrity Training for Contractors overheads and profits	%	6,000,000.00		
<b>TOTAL CARRIED FORWARD TO SUMMARY PAGE</b>					
<b>ACTIVITY V: SUPERVISORY COSTS</b>					
	<b>Item Description</b>	<b>Unit</b>	<b>Quantity</b>	<b>Unit Price (KSh)</b>	<b>Amount (KSh)</b>
6.1.1	Supply and Installation of Desktop Computers as per specifications	No	8		
6.1.2	Supply and Installation of Servers as per specifications	No	1		
6.1.3	Supply and Installation of Printers as per specifications	No	4		
6.2	Provide 4No. Digital Mobile Weighing Scales (2 for the Cluster and 2 for ALEHU Bases) and integrate the mobile weighbridges with the Weighbridge Management System for mobile network monitoring.	No	4		
6.3	Provide New Office Furniture at Webuye Weighbridge station including the police stations as detailed in the schedule attached in Appendix D and as shall be Instructed by the Engineer	No	1		
6.4	Construct 300mm thick continuously reinforced concrete pavement (CRCP) Holding Yard at Webuye using concrete class 30/20 as detailed in Appendix E and as shall be Instructed by the Engineer.	Item	1		
6.5	Material Testing as detailed in Appendix F and as shall be Instructed by the Engineer	Sum	1		
6.6	Allow a Prime Cost Sum of KSh 25,000,000.00 for facility improvement and maintenance in accordance with Annex A to be spent as directed by the Engineer in accordance with the schedules rates in this contract or as the Engineer shall direct.	L Sum	1	25,000,000.00	25,000,000.00
6.7	E.O 6.6 on for Contractor's overheads and profits	%	25,000,000.00		
<b>TOTAL CARRIED FORWARD TO SUMMARY PAGE</b>					

[October 2024]

<b>APPENDIX A FOR ITEM 4.4</b>					
		<b>Athiriver WB</b>	<b>Total for Cluster</b>	<b>Monthly Gross Salary per Staff</b>	<b>TOTAL</b>
<b>No.</b>	<b>Positions</b>				
4.4.1	Operations Manager	1	1		
4.4.2	Technical Manager	1	1		
4.4.3	Manager Weighbridge Cluster	1	1		
4.4.4	Assistant Weighbridge Manager (Static & mobile)	9	9		
4.4.5	Systems Administrators	3	3		
4.4.6	Operations and Maintenance Technician (Electrical)	3	3		
4.4.7	Operations and Maintenance technician (Electromechanical)	3	3		
4.4.8	Vehicle Inspector	6	6		
4.4.9	Computer Operator Weighing (COW)	12	12		
4.4.10	Computer Operator Prosecution (COP)	6	6		
4.4.11	General Assistant	12	12		
4.4.12	General Workers/Support Staff	2	2		
4.4.13	Security Guards	8	8		
	<b>Total Staff Per Cluster</b>	<b>67</b>	<b>67</b>		
E.O 4.4 for the contractor's overheads and profits					
<b>Total Monthly Labour Costs Carried to Item 4.4</b>					

[October 2024]

**APPENDIX B FOR ITEM 5.1****PART I****RATES FOR ENGINEERS SUPERVISORY STAFF**

NO.	DESIGNATION	KeNHA Grade	Rates						
			Wages & Salaries (Monthly)	Per Diem - Cluster 1 (Daily)	Per Diem -Cluster 2 (Daily)	Per Diem - Cluster 3 (Daily)	Field Allowance (Daily)	Transport Allowance (Daily)	Sample Engineer's Estimate
<b>1. Engineers</b>									
1	Director General			18,200.00	12,600.00	10,500	-	-	
2	Director			16,800.00	12,600.00	10,500	-	-	151,200.00
3	Resident Engineer (DD)/Deputy Director	3		16,800.00	12,600.00	10,500	-	-	1,209,600.00
4	Resident Engineer (AD)	4		14,000.00	10,500.00	8,400	-	-	84,000.00
5	Senior Engineer	5		14,000.00	10,500.00	8,400	-	-	945,000.00
6	Engineer	6		11,200.00	8,400.00	7,000	-	-	67,200.00
7	Senior Engineer (Projects)			6,300.00	4,900.00	4,200	-	-	
8	Engineer (Projects)			6,300.00	4,900.00	4,200	-	-	49,000.00
9	Assistant Engineer (Projects)			6,300.00	4,900.00	4,200	-	-	
10	Intern Engineer (Projects)			6,300.00	4,900.00	4,200	-	-	47,250.00
<b>2. Inspectorate</b>									

[October 2024]

1	Roads Superintendent	7		11,200.00	8,400.00	7,000	1,750.00	-	2,822,400.00
2	Roads Inspector	8		11,200.00	8,400.00	7,000	1,750.00	-	4,804,800.00
3	Roads Overseer	9		6,300.00	4,900.00	4,200	1,050.00	-	
4	Inspector (Projects)			6,300.00	4,900.00	4,200	-	500	68,600.00
5	Assistant Inspector (Projects)			6,300.00	4,900.00	4,200	-	500	
<b>3. Laboratory</b>									
1	Material Technologist			11,200.00	8,400.00	7,000	1,750.00	-	16,800.00
2	Lab Technician			6,300.00	4,900.00	4,200	1,050.00	-	9,450.00
3	Lab Attendant			6,300.00	4,900.00	4,200	1,050.00	-	9,450.00
4	Lab Technician (Projects)			6,300.00	4,900.00	4,200	1,050.00	-	
5	Lab Attendant (Projects)			6,300.00	4,900.00	4,200	1,050.00	-	
<b>4. Survey</b>									
1	Senior Surveyor	5		14,000.00	10,500.00	8,400	2,100.00	-	21,000.00
2	Surveyor	6		11,200.00	8,400.00	7,000	1,750.00	-	16,800.00
3	Senior Assistant Surveyor	7		11,200.00	8,400.00	7,000	1,750.00	-	16,800.00
4	Surveyor (Projects)			6,300.00	4,900.00	4,200	-	-	
5	Assistant Surveyor (Projects)			6,300.00	4,900.00	4,200	-	-	
6	CAD Technician (Projects)			6,300.00	4,900.00	4,200	-	-	

[October 2024]

7	Leveller (Projects)			6,300.00	4,900.00	4,200	-	-	
8	Chainman (Projects)			6,300.00	4,900.00	4,200	-	-	9,450.00
<b>5. Drivers</b>									
1	Senior Driver	8		11,200.00	8,400.00	7,000	1,750.00	-	688,800.00
2	Driver	9		6,300.00	4,900.00	4,200	1,050.00	-	1,014,300.00
3	Driver (Projects)			6,300.00	4,900.00	4,200	-	-	548,800.00
<b>6. Admin</b>									
1	Senior Officer	5		14,000.00	10,500.00	8,400	-	-	294,000.00
2	Legal Officer	6		11,200.00	8,400.00	7,000			817,600.00
3	ICT Officer	6		11,200.00	8,400.00	7,000			1,881,600.00
4	Officer	6		11,200.00	8,400.00	7,000	-	-	621,600.00
5	Senior Assistant Officer	7		11,200.00	8,400.00	7,000	-	-	235,200.00
6	Assistant Officer	8		11,200.00	8,400.00	7,000	-	-	235,200.00
7	Senior Office Assistant	9		6,300.00	4,900.00	4,200	-	-	274,400.00
8	Office Assistant	10		6,300.00	4,900.00	4,200	-	-	274,400.00
9	Accountant (Projects)			6,300.00	4,900.00	4,200	-	-	
10	Assistant Accountant (Projects)			6,300.00	4,900.00	4,200	-	-	
11	Procurement Officer (Projects)			6,300.00	4,900.00	4,200	-	-	

[October 2024]

12	Assistant Procurement Officer (Projects)			6,300.00	4,900.00	4,200	-	-	
13	Environmental Officer (Projects)			6,300.00	4,900.00	4,200	-	-	
14	Assistant Environmental Officer (Projects)			6,300.00	4,900.00	4,200	-	-	
15	ICT Officer (Projects)			6,300.00	4,900.00	4,200	-	-	
16	Assistant ICT Officer (Projects)			6,300.00	4,900.00	4,200	-	-	
17	Human Resource Officer (Projects)			6,300.00	4,900.00	4,200	-	-	
18	Asst. Human Resource Officer (Projects)			6,300.00	4,900.00	4,200	-	-	
19	Secretary (Projects)			6,300.00	4,900.00	4,200	-	-	
20	Office Assistant (Projects)			6,300.00	4,900.00	4,200	-	-	
21	Office Attendant (Projects)			6,300.00	4,900.00	4,200	-	-	
22	Casual Laborer (Daily)			1,000.00	1,000.00	1,000	-	-	
23	Intern			6,300.00	4,900.00	4,200	-	-	47,250.00
24	Attachee			6,300.00	4,900.00	4,200	-	-	
<b><u>7.</u></b>									
<b><u>Security</u></b>									
<b><u>(Police</u></b>									
<b><u>Officers)</u></b>									
1	Commandant	3		16,800.00	12,600.00	10,500			75,600.00
2	Senior Superintendent of Police (SSP)	5		14,000.00	10,500.00	8,400			126,000.00
3	Superintendent of Police (SP)	8		11,200.00	8,400.00	8,400			100,800.00

[October 2024]

4	Chief Inspector (CI)	8		11,200.00	8,400.00	8,400			
5	Inspector	8		11,200.00	8,400.00	7,000			
6	Senior Sergeant	8		11,200.00	8,400.00	7,000			
7	Sergeant	8		11,200.00	8,400.00	7,000			
8	Corporal	9		6,300.00	4,900.00	4,200			
9	Constable	10		6,300.00	4,900.00	4,200			
<b>SUB TOTAL A (Allowances Provision KeNHA Staff for the Contract Duration) = 17,584,350</b>									<b>17,584,350.00</b>

**PART II****KeNHA PROJECT STAFF RENUMERATION SCALE****1. TECHNICAL STAFF****Civil Engineering Degree Holders**

S/n	Staff Designation	Minimum Qualifications	Gross Monthly Remuneration (Man Months) (KShs)	No of Months	Total Amount	Sample Engineer's Estimate
1	Senior Engineer	i. Holds a Degree in Civil Engineering or its equivalent. ii. Registered <b>Professional</b> Civil Engineer with EBK and a <b>corporate</b> member of IEK. iii. Has Worked with KeNHA for over 3 years.	206,400.00			
2	Engineer	i. Holds a Degree in Civil Engineering or its equivalent from an institution recognized by EBK. ii. Registered <b>Graduate</b> Civil Engineer with EBK. iii. Has over <b>5 years Post-Registration</b> Experience in Roads. iv. Has Worked with KeNHA for over 3 years.		117,500.00	14	1,645,000
3	Assistant Engineer	i. Holds a Degree in Civil Engineering or its equivalent from an institution recognized by EBK.			93,500.00	14

[October 2024]

		ii. Registered <b>Graduate</b> Civil Engineer with EBK.			
		iii. Has over <b>3 years Post-Registration</b> Experience in Roads.			
		iv. Has Worked with KeNHA for over 2 years.			
4	Graduate Engineer	i. Holds a Degree in Civil Engineering or its equivalent from an institution recognized by EBK.	71,500.00	14	1,001,000
		ii. Registered <b>Graduate</b> Civil Engineer with EBK.			
		iii. Has over <b>1-year Post-Registration</b> Experience.			
5	Trainee Engineer/ Intern	i. Holds a Degree in Civil Engineering or its equivalent from an institution recognized by EBK.	25,000.00		
		ii. Registered or awaiting Registration as a <b>Graduate</b> Civil Engineer with EBK.			
		ii. <b>Fresh Graduate</b> from University.			
<b>Civil Engineering Diploma Holders</b>					
S/n	Staff Designation	Minimum Qualifications	Gross Monthly Renumeration (Man Months) (KShs)		
1	Superintendent	i. Holds a Diploma in Civil Engineering - Highways Category.	93,500.00		
		ii. Has over <b>6 Years Post graduation</b> Practical Experience in Roads.			
		iii. Has worked with KeNHA for over 4 years.			
2	Inspector	i. Holds a Diploma in Civil Engineering - Highways Category.	71,500.00	12	858,000
		ii. Has over <b>3 Years Post graduation</b> Practical Experience in Roads.			
		iii. Has worked with KeNHA for over 2 years.			
3	Assistant Site Inspector	i. Holds a Diploma in Civil Engineering - Highways Category.	52,500.00	12	630,000



[October 2024]

		ii. Has over <b>2 Years Post Graduation</b> Practical Experience in Roads.			
4	Trainee Site Inspector	i. Holds a Diploma in Civil Engineering - Highways Category.	30,000.00		
		ii. Fresh Graduate.			
<b>Construction/Project Management Degree Holders</b>					
S/n	Staff Designation	Minimum Qualifications	Gross Monthly Remuneration (Man Months) (KShs)		
1	Project Inspector	i. Holds a Degree in Project or Construction management or its equivalent.	71,500.00		
		ii. Construction Managers must be registered as Professionals with ACMK (Association of Construction Managers of Kenya) while Project Managers must be registered with KAPM (Kenya Association of Project Managers) and PMI (Project Management Institute) as professionals.			
		iii. Has over 5 Years Post Graduation Experience			
2	Assistant Project Inspectors	i. Holds a Degree in Project or Construction management or its equivalent.	52,500.00		
		ii. Construction Managers must be registered as Graduate members with ACMK (Association of Construction Managers of Kenya) while Project Managers must be registered with KAPM (Kenya Association of Project Managers)			
		iii. Has over 3 years post-Graduation Practical Experience			
3	Trainee Project Inspector	i. Holds a Degree in Project or Construction management or its equivalent.	30,000.00		
		ii. <b>Fresh Graduate</b>			

[October 2024]

<b>Surveyors</b>						
S/n	Staff Designation	Minimum Qualifications	Gross Monthly Renumeration (Man Months) (KShs)			
1	Senior Surveyor	i. Holds a Degree in Survey or its equivalent	204,600.00			
		ii. Registered as a Professional Member with the Institute of Surveyors of Kenya				
		iii. Has over 5 Years of Practical Experience in Roads.				
2	Surveyor	i. Holds a Degree in Survey or its equivalent	117,500.00			
		ii. Registered as a Graduate Member with the Institute of Survey of Kenya				
		iii. Has over 3 Years of Practical Experience in Roads.				
3	Assistant Surveyor/Leveller	i. Holds a Degree/Diploma in Survey or its equivalent	71,500.00			
		ii. Fresh from college				
4	Chainman	i. Has over 1 year of practical experience in roads survey	36,500.00			
<b>2. NON-TECHNICAL STAFF</b>						
<b>Finance Office</b>						
1	Assistant Accountant	Holds a Bachelors of Commerce (Finance & Banking) or its equivalent.	71,500.00			
		Holds atleast CPA-I				
		Has atleast 3 years post graduate practical experience.				
		Has worked with KeNHA for over 2 years.				
2	Trainee Accountant	Holds a Bachelors of Commerce (Finance & Banking) or its equivalent.	52,500.00	12	630,000	
		Fresh from university				
<b>Procurement Office</b>						
1	Procurement Officer	Holds a Degree in Supply Chain Management or its equivalent	117,500.00			
		Has over 3 years of experience.				

[October 2024]

		Has worked with KeNHA for over 2 Year			
2	Assistant Procurement Officer	Holds a Diploma in Supply Chain Management or its equivalent	71,500.00		
		Has worked with KeNHA for over 1 Year			
3	Trainee Procurement Officer	Holds a Degree/Diploma in Supply Chain Management or its equivalent	52,500.00		
		Fresh From college			
<b>Procurement Office</b>					
1	Information Communications Technology Officer	Holds a Degree in Information Technology, Computer Science/Engineering or any other relevant and equivalent qualification from a recognized Institution.	117,500.00		
		Has over 3 years of experience.			
		Has worked with KeNHA for over 2 Year			
2	Assistant Information Communications Technology Officer	Holds a Diploma in Computer Science, Information Technology or other relevant and equivalent qualifications from a recognized Institution	52,500.00	28	1,470,000
		Has worked with KeNHA for over 1 Year			
<b>Administration</b>					
1	Assistant Human Resource	Holds a Bachelor's Degree in Business Administration (Human Resource Management) or its equivalent.	71,500.00		
		Has worked with KeNHA for over 2 years.			
<b>Office Assistant</b>					
1	Office Assistant/Clerks	Has O-Level Certificate or its equivalent.	36,500.00	56	2,044,000
		Trained on data keeping and/or computer applications.			
<b>SUB TOTAL B = 9,587,000.00</b>					<b>9,587,000</b>
<b>Provision of a lump sum to be expended in overtime and allowances in accordance to Labour Laws and Human Resource procedures &amp; guidelines (30% of Sub Total B) = 2,876,100.00</b>					<b>2,876,100</b>
<b>SUB TOTAL C (SUBTOTAL B + Provisional Sum for Overtime and Allowances) = 12,463,100.00</b>					<b>12,463,100</b>
<b>GRAND TOTAL CARRIED FORWARD TO ACTIVITY 5 (SUB TOTAL A + SUB TOTAL C) = 30,047,450.00</b>					<b>30,047,450</b>

[October 2024]

**APPENDIX C FOR ITEM 5.3****RE's OFFICE MISCELLANEOUS EXPENSES**

<b>1. Stationary &amp; Consumables</b>					
<b>NO.</b>	<b>DESCRIPTION</b>	<b>UNIT</b>	<b>Quantity</b>	<b>Rate (Ksh)</b>	<b>Amount (Ksh)</b>
1	A3 Photocopy Papers (White)	Reams	10		
2	A4 Photocopy Papers (White)	Reams	10		
3	A4 Photocopy Papers (Coloured)	Reams	10		
4	Paper Conqueror Laid A4 (Blue, Cream)	Reams	10		
5	Counter Books A4 (4 Quire)	No.	5		
6	Paper Punch Medium	No.	5		
7	Paper Punch Giant	No.	5		
8	Stick notes (Sign here)	No.	5		
9	External Hard Disk 500GB	No.	5		
10	External Hard Disk 1TB	No.	5		
11	Flash Disk 32GB	No	5		
12	Pvc Box File (Medium)	No	100		
13	Scientific Calculator	No	5		
14	Cordless Mouse	No	5		
15	Uni-ball pens (Blue/Black)	Dozen	10		
16	Quality Envelopes (A4)	9gsm	18		
17	Quality Envelopes (A3)	90gsm	18		
18	Sticky Notes	No	18		
19	Binder clips (medium, Large)	Pkt	10		
20	Binding Spirals (10mm)	pcs	10		
21	Binding spirals (16mm)	pcs	10		
22	Binding Spirals (22mm)	pcs	10		
23	Binding Spirals (25mm)	pcs	10		
24	Binding Spirals (28mm)	pcs	10		
25	Staple Pins 24/6	Pkts	5		
26	Staple Pins Giant	Pkts	5		
27	Pencils	Dozen	5		

[October 2024]

28	Embossed Covers (Blue & Green)	Reams	5		
29	Short Hand Note Books	No.	20		
30	Biro Pens (Bic)	Dozen	10		
31	Branded Shirts/Blouses	No.	15		
33	Branded hoodie	No.	15		
34	Delivery Book	No.	5		
35	Orthopedic Chair	No.	5		
36	Safety Boots	No	10		
37	Reflector Jackets	No	10		
38	Bottom Load Water Dispenser	No.	1		
39	Desk Organizers	No.	3		
40	Stapler Giant	No.	2		
41	Hp Toner Black 203A (CF540A)	No.	5		
42	Hp Toner Cyan 203A (CF541A)	No.	5		
43	Hp Toner Magenta 203 A (CF543A)	No.	5		
44	Hp Toner Yellow 203A (CF542A)	No.	5		
46	Toner TK8525K	No.	5		
47	Toner TK8525M	No.	5		
48	Toner TK8525Y	No.	5		
49	Toner TK8525C	No.	5		
50	Hp Toner-Black 312X-CF380X for HP LaserJet MFP M476dw	No.	5		
51	Hp Toner-Cyan 312 X (CF381X) for HP LaserJet MFP M476dw	No.	5		
52	Hp Toner-Magenta 312X (CF383X) for HP LaserJet MFP M476dw	No.	5		
53	Hp Toner- Yellow 312X (CF382X) for HP LaserJet MFP M476dw	No.	5		
54	Hp Toner - Black 305A (CF410A) for HP LaserJet 400 MFP M475dn	No.	5		
55	HP Toner-Cyan 305A-(CF411A) for HP LaserJet 400 MFP M475dn	No.	5		

[October 2024]

56	HP Toner-Magenta 305A -(CF411A) for HP LaserJet 400 MFP M475dn	No.	5		
57	HP Toner-Yellow 305A-(CF411A) for HP LaserJet 400 MFP M475dn	No.	5		
58	Extension Cables with Power Surge	No	3		
59	Hp Toner-Yellow 205A (CF532A) for HP Color LaserJet Pro MFP M180n	No	5		
60	Hp Toner- Black 205A (CF530A) for HP Color LaserJet Pro MFP M180n	No	5		
61	Hp Toner-Cyan 205A (CF531A) for HP Color LaserJet Pro MFP M180n	No	5		
62	Hp Toner-Magenta 205A (CF533A) for HP Color LaserJet Pro MFP M180n	No	5		
<b>2. Staff Welfare</b>					
	-	-	-		
1	Assorted Beverages	Packets	5		
2	Milk (Fino) 500ml	Cartons	300		
3	Sugar	Kgs	144		
5	Disposal Cups 300ml	Packets	100		
6	Cling film	No.	10		
7	JIK	1 Ltr.	5		
8	Bar Soap	1 kg	3		
9	Washing Soap (Axion)	Tins	10		
10	Tissue Papers	Dozen	5		
12	Refillable Drinking Water(20Ltrs)	20 Litres	200		
13	Velvex Kitchen Premium kitchen towels 2pack	No.	5		
14	Paper Serviette	No.	10		
15	Dish Towels	No.	5		
16	Facial Tissue/Wet wipes	No.	10		
17	Air Wick Automatic spray refill	No.	6		
18	Handwash/Sanitizer	No.	5		

[October 2024]

19	Air freshener	No.	5		
20	Thermos Flasks	No.	2		
21	Spoons/ Folks	12 pack	5		
22	Cups	Dozen	5		
23	Glass	Dozen	5		
24	Electric Kettle	No	1		
25	Sugar dish	No.	5		
26	Tray	No.	5		
27	Airtime for staff (Each 1000)	No	400		
28	Snacks/Fruits per person	No	200		
29	Gas Refill (13Kg)	No	10		
30	Go TV Subscription	Monthly	28		
31	Lunches (per plate)	No	200		
<b><u>3. Air Travels</u></b>					
32	Allow Air Tickets for Officers	No.	70		
	<b>Total</b>				
	<b>GRAND TOTAL CARRIED FORWARD</b>				

[October 2024]

<b>APPENDIX D FOR ITEM 6.3</b>					
<b><u>New Office Furnitures</u></b>					
<b>NO.</b>	<b>DESCRIPTION</b>	<b>UNIT</b>	<b>Quantity</b>	<b>Rate (Ksh)</b>	<b>Amount (Ksh)</b>
6.3.1	15 seat Race truck Conference Tables with 15 Chairs	No.	1		
6.3.2	Office Desk on Panel Legs Complete with Extension and Drawers Mobile Pedestal (L 1.6M X W 0.8M X H 0.75M) >	No.	15		
6.3.3	3 Door File cabinets (L 0.85M X W 0.4M X H 1.8M)	No.	10		
6.3.4	High Back Chairs with Adjustable Arms, Headrest, Height, Tilt and Locking	No.	30		
6.3.5	Visitors Chairs - Cantilever visitor chair in PU leather on chrome metal base. (Medium Back-Black)	No.	2		
6.3.6	Executive Leather Chairs	No.	2		
6.3.7	Double Pedestal Executive Desks	No.	2		
6.3.8	Office Coat Hangers	No.	8		
<b>TOTAL</b>					
<b>GRAND TOTAL CARRIED FORWARD ITEM 6.3</b>					



[October 2024]

<b>Appendix E: Bill Item No 6.4 - Construction Holding Yard at Webuye Weighbridge Station Malaba bound.</b>					
	<b>Description</b>	<b>Unit</b>	<b>Quantity</b>	<b>Unit Price</b>	<b>Total Price</b>
	<b>Construction Holding Yard at Webuye Weighbridge Station Malaba bound.</b>			<b>Kshs.</b>	<b>Kshs.</b>
<b>A</b>	<b><u>EARTH WORKS</u></b>				
6.4.1	Cut to spoil	m3	12,500.00		
6.4.2	Cut in hard	m3	625.00		
6.4.3	Fill in soft	m3	5,000.00		
6.4.4	Fill in hard	m3	1,250.00		
6.4.5	Allow for rock fill	m3	1,875.00		
<b>B</b>	<b><u>CONSTRUCTION</u></b>				
6.4.6	Provide, lay and compact to 100% M.D.D 300mm thick S5 subgrade material (CBR>22.5%)	M <sup>3</sup>	3,750.00		
6.4.7	Provide, lay and compact 200mm thick approved graded crushed stones (GCS) as Subbase 2 to Engineers Specifications	M <sup>3</sup>	2,500.00		
6.4.8	Provide, lay and compact 150mm thick Improved graded crushed stones (GCS) as Subbase 1 to Engineers Specifications	M <sup>3</sup>	1,875.00		
6.4.9	Provide, transport and spread cement stabilizer on graded crushed stones (GCS) for Subbase 1	Tons	67.50		
6.4.10	Curing of treated layers.	M <sup>2</sup>	25,000.00		
<b>C</b>	<b><u>CONCRETE WORKS</u></b>				
6.4.11	Construct 300mm continuously reinforced concrete pavement (CRCP) to the Holding Yard and Loops with concrete Class 30/20.	M <sup>3</sup>	3,750.00		
6.4.12	Unformed Surface finishes	M <sup>2</sup>	12,500.00		
6.4.13	Formwork to edges of slabs	M <sup>2</sup>	350.00		
<b>D</b>	<b><u>REINFORCEMENT</u></b>				
6.4.14	12mm diameter deformed steel bars for Traverse and Longitudinal reinforcement at 200mm spacing.	KG	111,000.00		
<b>E</b>	<b><u>ROAD FURNITURE</u></b>				
6.4.15	Provide and paint 0.1m wide thermoplastic white lines with glass beads on edges and parking	M <sup>2</sup>	125.00		
6.4.16	Provide cat eyes	No	25.00		
<b>Total</b>					
<b>Total of Item No 6.4 carried forward to the Bill of Quantities</b>					

[October 2024]

**CONSTRUCTION OF 300MM THICK CONTINUOUSLY REINFORCED CONCRETE PAVEMENT (CRCP) HOLDING YARD AT WEBUYE USING CONCRETE CLASS 30/20**

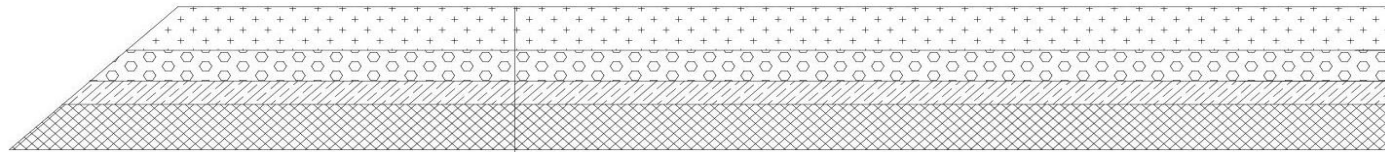

- CRPC Concrete C30 (300mm)
- Polythene sheet
- Subbase 1 [Improved GCS] (150mm)
- Subbase 2 [GCS] (200mm)
- Subgrade [IGS] (300mm)

- NOTES**
1. The Holding Yard shall be constructed for length 120m by width 40m
  2. All Measurements are in mm
  3. The Rigid pavement shall be reinforced longitudinally with 16mm steel deformed bars at 150mm max spacing and transversely with 12mm skew deformed bars at 200mm spacing
  4. The Pavement shall have a smooth finish
  5. The Concrete panels shall be 3.5m wide and 8m long each.

 KENYA NATIONAL HIGHWAYS AUTHORITY DIRECTORATE OF MAINTENANCE DEPARTMENT OF AXLE LOAD CONTROL	APPROVED BY: Eng. Dr. M.N	Date:	NO.:	Date:	REVISIONS:	By:	Dwg. No.:	REFERENCE Dwg.:	DIRECTOR MAINTENANCE (ENGINEER):	 Kenya National Highways Authority Quality Highways, Better Connections KENYA NATIONAL HIGHWAYS AUTHORITY BARAKA PLAZA BLOCK A & C, JHA P.O. BOX 49712 - 00100 NAIROBI, KENYA	Project Title: Construction of 300mm thick continuously reinforced concrete pavement (CRCP) Holding Yard at Webuye using concrete class 30/20		
	CHECKED BY: Eng. K.N	Date:	1	SEP-24			Dwg. No: WMC4-01	Dwg. No: WMC401	DEPUTY DIRECTOR AXLE LOAD CONTROL (RESIDENT ENGINEER):		TYPICAL PAVEMENT CROSS-SECTION	RIGID STEEL REINFORCED CONCRETE PAVEMENT FOR THE HOLDING YARD	
	DESIGNED BY:	Date:							SENIOR ENGINEER:		SCALES (A3 Scale)	AS SHOWN	DATE: SEPTEMBER 2024
	DRAWN BY: D.N	Date:											Dwg. No: WMC401

[October 2024]

<b>Appendix F: Bill Item 6.5 - Material Testing as shall be Instructed by the Engineer</b>				
<b>S/No.</b>	<b>Description</b>	<b>Frequency</b>	<b>Cost per Test (Kshs)</b>	<b>Total Amount (Kshs)</b>
<b>CEMENT AND CONCRETE</b>				
6.5.1	Cube Crushing per Cube	15		
6.5.2	Making and Crushing of Concrete cubes (set of 3)	15		
6.5.3	Core Crushing Strength and capping	15		
6.5.4	Cement Strength (Cube Test)	15		
6.5.5	Cement Soundness	15		
6.5.6	Concrete mix Design (Complete)	3		
<b>COARSE AGGREGATES</b>				
6.5.7	Flakiness Index (FI)	5		
6.5.8	Bulk Density	5		
6.5.9	Los Angeles Abrasion Test (LAA)	5		
6.5.10	Aggregates Crushing Value (ACV)	5		
6.5.11	Aggregates Impact Value (AIV)	5		
6.5.12	Sieve Analysis (Gradation)	5		
6.5.13	Water Absorption	5		
6.5.14	Specific Gravity (SG)	5		
6.5.15	Silt and Clay Content	5		
6.5.16	Soluble Chloride Content	5		
6.5.17	Sodium Sulphate Soundness (SSS) AASHTO T104 (ASTM C88)	5		
<b>FINE AGGREGATES</b>				
6.5.18	Bulk Density	5		
6.5.19	Sieve Analysis (Gradation)	5		
6.5.20	Water Absorption	5		
6.5.21	Specific Gravity (SG)	5		
6.5.22	Silt and Clay Content	5		
6.5.23	10% Fines	5		
6.5.24	Weathering 5 cycles (SSS)	5		

[October 2024]

6.5.25	Sand Equivalent	5		
6.5.26	Organic impurities in sands	5		
	<b>SOIL ANALYSIS</b>			
6.5.27	Moisture content	5		
6.5.28	Determination of Liquid Limit, Plastic Limit, Plasticity Index and Linear Shrinkage (Atterberg's Limits)	5		
6.5.29	Particle size distribution (Hydrometer analysis and Wet Sieving)	5		
6.5.30	Compaction test, Maximum Dry Density (MDD) using a 2.5kg rammer (AASHTOT99)	15		
6.5.31	Compaction test, Maximum Dry Density (MDD) using a 4.5 kg rammer (AASHTOT180).	15		
6.5.32	Field Dry Density (FDT)	15		
6.5.33	California Bearing Ratio, CBR statically compacted to 100% MDD, OMC AT 4 Day soak	7		
6.5.34	California Bearing Ratio, CBR at 95% MDD (AASHTO T180) and 4 days soak	7		
6.5.35	California Bearing Ratio, CBR for stabilized samples	7		
6.5.36	Determination of specific gravity	5		
6.5.37	Unconfined Compressive Strength, UCS test	5		
6.5.38	Organic matter content	7		
6.5.39	Uniformity Coefficient	7		
	<b>OTHERS TESTS</b>			
6.5.40	Chemical Analysis of Lime	2		
6.5.41	Chemical Analysis of Cement	2		
6.5.42	Suitability Cat eyes	2		
<b>Total of Item No 6.5 carried forward to the Bill of Quantities</b>				

[October 2024]

**TECHNICAL SPECIFICATION FOR VARIOUS ICT EQUIPMENT (Bill Items 6.1.1, 6.1.2 & 6.1.3)**

<b>Item</b>	<b>Minimum Specification</b>
<b>Desktop Computers (8 No)</b>	Processor: Intel® Core™ i7 (up to 4.2 GHz, 8 MB L3 cache, 4 Cores), Memory 16 GB DDR4, Hard Disk: 1TB HDD, Display Monitor 24" Anti-glare; UPS 750 VA, Office Software Windows 10, Microsoft Office 2019, Anti-Virus
<b>File and Backup Solution Server (1 No)</b>	<b>Form Factor</b> 2U rack, <b>Processor</b> 3.8 GHz 4 Cores 16.50 MB cache, <b>Configured Disk</b> Hot Plug SFF SAS HDD (12 X 2.4TB), <b>Memory</b> 32GB (2 x 16GB), <b>Mem Management Network Port</b> 1 Gb Dedicated, Windows Server Standard 2019, <b>Network Controller</b> Embedded 2-Port 1GbE, <b>Smart Array</b> 1 HPE Smart Array P408i-a SR Gen10 Ctrlr, 1 HPE DL180 Gen10 SFF Box3 to -a Cbl Kit, 1 HPE 96W Smart Storage Battery 145mm Cbl, 1 HPE 500W FS Plat Ht Plg LH Pwr Sply Kit
<b>Printer (4 No)</b>	<b>Print speed letter: Up to 40 ppm (black), Print Technology Laser, Processor speed 800 MHz, Paper trays standard 4, Ports 1 Hi-Speed USB 2.0 Device; 1 Gigabit Ethernet 10/100/1000 Base-T; 1 Hi-Speed USB 2.0 Easy Access USB, Paper handling output 250, Paper handling input 100.</b>

[October 2024]

# TECHNICAL SPECIFICATION FOR DIGITAL MOBILE SCALES (HAENNI OR EQUIVALENT ALTERNATIVE) (Bill Item 6.2)

The Digital mobile scales should have a range of 0-15t, WL 108/15t standard execution, WL 108/411.111/20Y.  
Levelling mats 2.8m x 17mm D 12535.0

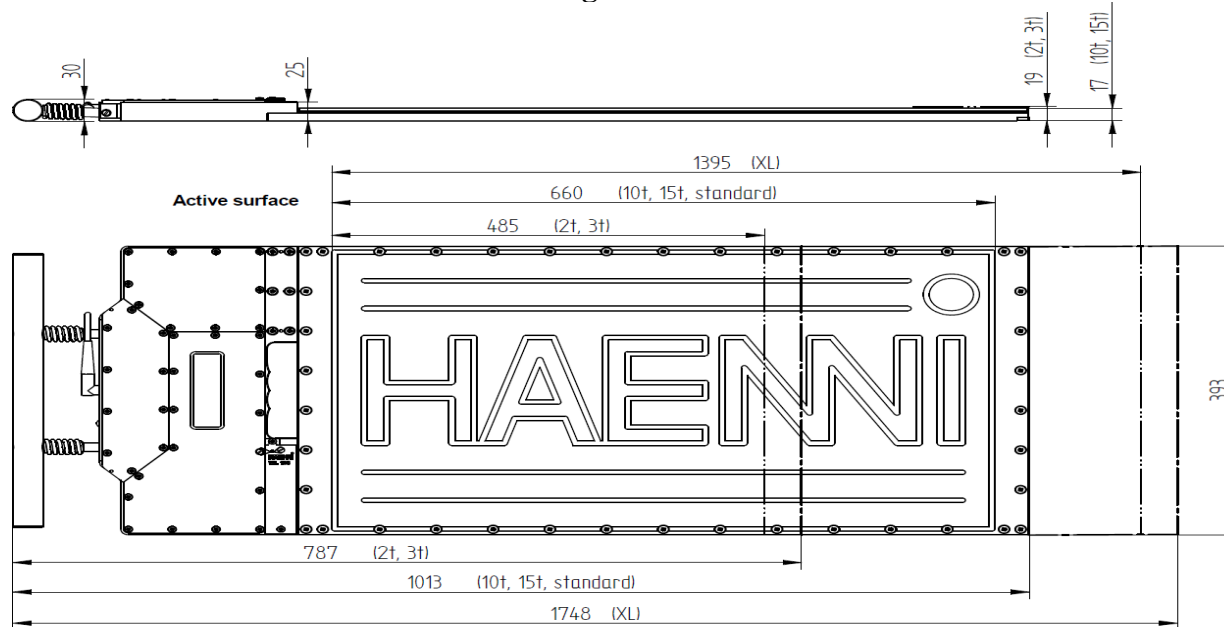

[October 2024]

Range	0...2 t		0...3 t	0...10 t		0..15 t	
Division (standard / smaller <sup>3)</sup> )	10 kg	5 kg	10 kg	50 kg	20 kg <sup>5)</sup>	100 kg	50 kg <sup>5)</sup>
Accuracy on calibration	standard Division		± 5 kg (up to 500 kg) ± 10 kg (500 kg..2000 kg)	± 5 kg (up to 500 kg) ± 10 kg (500 kg..2000 kg) ± 15 kg (2000 kg..3000 kg)	± 25 kg (up to 2,5 t) ± 50 kg (2,5t...10t)		± 50 kg (up to 5t) ± 100 kg (5t...15t)
	smaller Division		± 2,5 kg (up to 250 kg) ± 5 kg (250 kg...1000 kg) ± 7,5 kg (1000 kg ...2000 kg)	-----	± 10 kg (up to 1t) ± 20 kg (1t...4t) ± 30 kg (4t...10t)		± 25 kg (up to 2,5t) ± 50 kg (2,5t...10t) ± 75 kg (10t...15t)
in operation	twice the tolerance at calibration						
Loading limit	2,5 t		3,75 t	12,5 t		18 t	
Permissible load per area	6 kg/cm <sup>2</sup>		9 kg/cm <sup>2</sup>	12 kg/cm <sup>2</sup>		15 kg/cm <sup>2</sup>	
Loading limit per area	12 kg/cm <sup>2</sup>		18 kg/cm <sup>2</sup>	24 kg/cm <sup>2</sup>		30 kg/cm <sup>2</sup>	
Operating temperature	-20...+60 °C		-20...+60 °C				
Storage temperature	-30 .....+60 °C						
Electromagnetic susceptibility	OIML Nr. 76 <sup>1)</sup>						
Zero tracking, test etc..	automatic according OIML Nr. 76 <sup>1)</sup>						
Type of protection (ICE 144)	IP 65						
Overrunable	completely overrunable incl. cable						
Operating site	Firm and level ground, max. 10 mm bend through, max. 5% slope (≈ 3°)						
Active surface	in driving direction		345 mm		380 (12 kg/cm <sup>2</sup> ) <sup>2)</sup> 393 (6 kg/cm <sup>2</sup> ) <sup>2)</sup>	380 (15 kg/cm <sup>2</sup> ) <sup>2)</sup> 393 (6 kg/cm <sup>2</sup> ) <sup>2)</sup>	
	across to driving dir.		see sketch				
Over all dimensions	see sketch						
Power supply	Integrated battery for 180 h service <sup>4)</sup> Recharge (12 - 24) and operation (5 - 12 V) from 12V car battery or AC adapter						

[October 2024]

## SECTION 5. -TERMS OF REFERENCE

### 5.0 BACKGROUND INFORMATION

#### 5.1 General

The Kenya National Highways Authority (KeNHA) has earmarked funds through the Fuel Levy Budget for use in engaging the services of a Contracting Firm to undertake the Management, Operations and Maintenance of Webuye Weighbridge Station and the 2073 Km Adjacent Road Network.

KeNHA shall require the bidder to render all technical support services which may be deemed relevant to the above work. The detailed descriptions of the contracting services to be performed are as described in these Terms of Reference (TOR).

#### 5.2 Selection Criteria

The bidder selected to undertake the operations management shall have had extensive experience in the management operations of technical facilities.

#### 5.3 Project Description

##### 5.3.1 Project Location

The works are located at the site of the existing weighbridge stations at Webuye and the 2073 Km Adjacent Road Network along the existing national trunk roads.

The site of the works shall be the area within the compound of the Weighbridge station and the following routes to be surveilled by two (2) mobile weighbridge units.

No	From	To	Road Class	Approximate Road Length (Km)
1.	Kakamega - Webuye-Kitale	Lodwar - Nadapal-Lokitaung	A1	451.80
2.	Malaba-Webuye	Webuye - Mausummit	A8	138.99
3.	Lokichar	Amosing	A10	31.00
4.	Jnct A1[Makutano]	Kaaling	B117	18.20
5.	Eldoret	Kapsabet	B8	40.20
6.	Kakamega-Ekero-Chepsonoi-Kapsabet	Chebarbar-Lessos-Nabkoi	B12	154.60
7.	Chemolingot-Barpello	Marigat-Loruk	B17	85.10
8.	Kapcherop	Naiberi - Kapchorwa	B122	126.40
9.	Cheptiret	Kimondi	B123	13.60
10.	Eldoret - Nyaru	Kapkayo - Tenges	B124	41.00
11.	Kapsokwony-Namwela-Sirisia	Malaba-Busia	B13	97.90
12.	Chemelil	Muhoroni-Fort Tenan	B132	116.31
13.	Bungoma-Namakoye-Kakamega	Mungatsi-Bungoma	B137	72.07
14.	Mayoni-Bungoma	Mayoni-Bungoma	B139	27.00
15.	Maili Tisa	Kitale	B14	55.00
16.	Ebuyangu	Ekero	B140	30.00
17.	Malakisi-Lwakhakha	Mungatsi-Malakisi	B141	42.06



[October 2024]

No	From	To	Road Class	Approximate Road Length (Km)
18.	Bungoma-Chwele	Namwela-Kamukuywa	B142	52.50
19.	Marigat-Kabarnet-Iten	Kachibora- Sibanga- Kitale	B15	117.00
20.	Loima	Lodwar A	B70	12.00
21.	Lokichogio	Lokitaung(A)	B71	5.00
22.	Lodwar	Kalokol	B72	56.90
23.	Kapenguria	Konyao	B70	80.00
24.	Kamwosor-Nyaru-Iten	Chebiemit-Kamatira	B77	207.90
<b>TOTAL</b>				<b>2073</b>

The contract will involve management, operation and maintenance of the physical facilities, Maintenance of weighbridge equipment, equipment verification and calibration, collection and dissemination of weight data, maintenance of weighing scales, computer software and hardware, assistance to Law Enforcement Authorities and any other works as directed by the Engineer.

#### 5.4 CONTRACT OBJECTIVES

The overall objectives of the project are to attain a sustainable and safe road network by ensuring that the axle loads applied to road pavements are not exceeded, in order to minimise the damage to roads and bridges and level the playing field for the conduct of transport business in and around the country.

The contract will involve management, operation and maintenance of the physical facilities, provision and maintenance of weighbridge equipment, equipment verification and calibration, collection and dissemination of weight data, maintenance of weighing scales, computer software and hardware, assistance to Law Enforcement Authorities and any other works as directed by the Engineer.

The specific objectives of this contract are to ensure that the axle loading on the highways is monitored by enforcing legal axle and vehicle loading limits. The infrastructure at the static weighbridge stations and the scales for the mobile units will be managed and maintained to the highest standards within the contract period.

The services to be provided by the Contractor shall include but not be limited to the following:

- (i). Supply and installation of new computers including the applicable software and their licences and maintenance.
- (ii). Provision of primary and secondary Internet Link with a capacity of **50MBPS** with dedicated connectivity per site in each cluster. This shall include provision of a Wide Area network for all the sites within the cluster and KeNHA Headquarters. The redundant / secondary backup connectivity shall be from a separate internet service provider. **One link shall be via fibre optic and the other one a wireless connection for continuous flow of data in case of fibre cut.** The Primary and Secondary Internet Links shall be approved by the Engineer. This shall include provision of Security and Business Continuity for All weighbridge ICT Systems which includes Backups, ICT Security, Firewalls, Antivirus in line with Authority's ICT Policy requirements. **The Management Contractor shall ensure continuous data stream to KeNHA Headquarter servers and cloud storage. Internet Speed Test print outs to be attached as proof of compliance for payments to be made.**

[October 2024]

- (iii). Operate and maintain the Weighbridge Stations within the Cluster. Maintenance shall include all items contained in ANNEX C, telephones, use and replenishment of all consumables, Office Furniture, ICT Infrastructure, installed Computer & Servers Hardware and Software including licences, Public Address and Public Display Systems, Maintenance of the compound and the office facilities and road reserve through grass cutting to a maximum height of 50mm, bush clearing, opening of drains and culverts, general tidiness of the weighbridge cluster stations and watering of flowers beds. Maintenance shall be on a continuous twenty-four-hour basis. The Management Contractor Shall **include in his rates for Operation and Maintenance of the Weighbridges for Private Security guards (from a reputable Security Firm)** required to man all key installations including High Speed Weigh in Motion Equipment gantries, Street lights and gates, provision of clean water & sewerage services, telephones and data communication services. However, the private security providers shall be approved by the Engineer before they can be deployed into the weighbridges.

*Failure to Maintain or Provide any of the listed activity/items shall attract a daily penalty of KSh.100,000.00 per Item after the third day of failure occurrence. It is the duty of the Management Contractor to keep spares of frequently breaking parts to avoid disruption of weighbridge operations. Equipment failures involving multi-deck scales, High Speed Weigh In Motion (HSWIM), computers, booms, remote display units, etc shall be addressed within 24 hours of such failure occurring otherwise the penalty specified in this paragraph shall apply.*

The Operation and Maintenance Period shall be 28 months, including;

Phase 1: Operations management – 27 months.

Phase 2: Finalising Operations and Handing over – 1 month.

There shall be atmost 1-month Shadowing Phase for Taking over the facilities before the Contract commencement date. This is to allow a smooth Handover of operations within the facilities. **The Management Contractor shall include in his rates costs for the Shadowing Period especially for the skeleton but key staff for the continuity of the weighing and prosecution processes.**

- (iv). Payments of Monthly Electricity Bills to Kenya Power and Lighting Company (KPLC). In case of outage of grid power, the Management Contractor shall use Generators for continued Weighbridge Operations. Reimbursements to Contractor shall be on the amount paid to KPLC and Generator Hours. The generator running logs shall be provided for this purpose. **The Contractor shall ensure that the availability of power to run the station is guaranteed 100% of the time. Availability of power below this requirement shall automatically attract a daily penalty of KSh.100,000.00. The minimum fuel levels for each of the Generators shall be half tank the capacity of the generator at the station failure to which penalties in this clause shall apply.**
- (v). Payments to facilitate effective Contract Supervision by the Engineer's Representative **The Management Contractor shall ensure timely release of payments to facilitate the delivery of services.** These shall be instructed by the Engineer's Representative to facilitate those officers attending court, salaries and allowances payable to the Engineer's staff. **The Contractor shall put in place mechanisms to facilitate efficient release of such funds to the officers not later than three working days after the receipt of such instructions. Salaries and monthly allowances shall be paid by the last day of the due month. Any delays arising thereof shall result in non - payments of the Contractor's extra over item for overheads and profits at the rate quoted by the Contractor for the item in the subsequent month. This is notwithstanding, a daily deduction of KSh 100,000 (One**

[October 2024]

*Hundred Thousand Shillings) for each day the Salaries are delayed after the last day of the month.* This is intended to enhance integrity among staff as they carry out their duties and to avoid non-attendance to matters coming up in court.

*The Engineer's Representative shall forward to the Contractor the details of all his staff engaged in the project. The Contractor shall issue the staff with formal appointment letters and the Contractor shall make statutory deductions from all payments made to such staff and remit to the relevant bodies. The proof of remittance must be attached to IPCs to qualify for payment.*

- (vi). In liaison with the Police, depending on the level of weighbridge automation, direct to the scales, and weigh each axle of all load-carrying vehicles with a loading capacity of 3500kgs and above
- (vii). Weighing all vehicles with a Gross Vehicle Weight of 3500kgs and above. Vehicles cleared by the High-Speed Weigh in Motion (HSWIM) shall be allowed to proceed. The Called-in Vehicles shall have their weights confirmed at the Multideck/SAW Scales for appropriate action. The Management Contractor shall record all vehicles which transgress. The Transgression records shall be kept for all offences and transmitted in the format required by prosecuting authorities. *For purposes of compliance with the directive to allow Transit trucks passage at the intermediate stations, the Management Contractor shall ensure that ALL Transit trucks cleared at their first point of entry shall be cleared by HSWIM to proceed and only impounded at the point of exit. Where the station is a point of entry, no Transit Trucks shall be granted passage unless they are compliant.*

**The Management Contractor shall be surcharged an amount equivalent to five times the applicable fine/or overload fee of the overload as prescribed in the EACVLC, 2016 or the Traffic Act if any vehicle is impounded with overload after passing a static weighbridge under his/her management unless they are Transit Trucks as indicated above. The Management Contractor shall be responsible for enforcing the applicable legal regime on networks under their watch. Only trucks found on Regional Trunk Road Network shall be subjected to the provisions of the East African Community Act, 2016 and its attendant Regulations. The Contractor shall be responsible and shall meet the costs and liabilities accruing from the misapplication of the applicable Statutes.**

*The rates entered by the Contractor in Activity I under the breakdown of costs should take consideration of the above. No separate payments shall be made for provision of facilities incidental to the main objective of the Assignment – Axle Load Control.*

- (viii). Impound and facilitate the Prosecution of overloading cases reported by the Virtual Weighbridges within the Cluster.
- (ix). Attendance to court to give evidence for matters prosecuted in court. These shall include cases arising from Static Stations, Mobile and Virtual Weighbridges. The Management Contractor shall include in his rates facilitation for his Staff to attend Court for cases arising during the New Management Contract Period.
- (x). Collect, compile and analyse vehicle traffic and axle-load data and forward the data to the Engineer in a report as prescribed in **ATTACHMENT A**. This shall include daily, weekly, monthly, quarterly and annual management reports. These will be submitted electronically to the Engineer's Representative in form of short message service (SMS), email and hard copies. The Management Contractor **shall prepare the Final report, at the end of the 28 months contract period**, together with lessons learned and recommendations to the Employer through the Engineer.

[October 2024]

**NOTE: The Rates entered by the Contractor in Activity I under the Breakdown of Costs SHOULD take Consideration of the Above. NO Separate Payments SHALL be made for this.**

- (xi). Submit weekly reports of incidences to the Engineer recommending action if any.
- (xii). Forward the monthly weighbridge data detailing the number of vehicles passing the station as captured by our system, those diverted and weighed, overloaded and impounded trucks, court cases and processes undertaken, vehicles impounding through mobile monitoring with overloads of more than two (2) tonnes, number of verified exemption permits to the Engineer.
- (xiii). Maintain law and order, through the Kenya Police and private security at the weighbridge station.
- (xiv). Organising for regular meetings in consultation with the Engineer with stakeholders such as drivers, transporters, cargo owners and cargo generation points to disseminate information about Compliance with Axle Load Limits. The Management Contractor shall coordinate with other government agencies such as the Courts, KRA, KPA, NTSA, EACC during the execution of the Contract.
- (xv). Organise for regular training of his staff. These shall include; Weighbridge Management System, Integrity Awareness Training by relevant internal and external bodies, Axle Load Laws training, Compliance with ISO standards, Customer Relations etc. The Contractor shall carry out HIV/AIDS awareness campaigns in liaison with the Ministry of Health.
- (xvi). Facilitate continuous engagement with the Courts through organized cluster retreats, CUCs, visits to individual Courts, Periodic Stakeholders Meetings, Media Communication Sensitization and other facilitations.
- (xvii). Facilitate for facility improvement and maintenance to be spent as directed by the Engineer in accordance with the schedules rates in this contract or as the Engineer shall so choose to source competitively from the market at the prevailing rates at the time. The Works shall be carried out in Accordance with clause 59.1, 59.2, 59.3, 59.4 & 59.5 of the Conditions of Contract. The entered rates shall include overheads and profits. Provisional sums (including Dayworks) in the Bills of Quantities shall be expended in whole or in part at the discretion of the Engineer.
- (xviii). The Weighbridges are currently operating on KenLoad Version 2 Weighbridge Management System which is also Integrated with the Virtual and Mobile Weighbridges.  
The Management Contractor shall propose and facilitate with the approval of the Engineer the **upgrades of the Weighbridge Management Software which is registered under KeNHA including the Maintenance fee for a period of 28 Months.**
- (xix). Maintain the physical facilities including offices in good state of repair as instructed by the Engineer.
- (xx). Repairs and calibrations of all hardware. **The weighing Equipment shall be Calibrated Quarterly or as Instructed by the Engineer. This shall be done by the Weights and Measures Department. A Certificate of Calibration shall then be issued to the Client after every calibration exercise and another copy displayed at the Weighbridge Station.**  
The Contractor shall prepare a maintenance schedule of all the equipment at the weighbridge facilities for approval by the Engineer before commencement of works. Calibrating and servicing of weighbridge equipment shall be done after **every three (3) months** or whenever repairs are carried out, whichever occurs first.
- (xxi). Maintenance of communications and data sharing with the Virtual Weighbridges Control Centre at KeNHA Headquarters and Mobile Weighbridge operations.
- (xxii). Maintenance of the scale approach and ramps, entrance and exit roads to the Weighbridge Station and office buildings in the compound.

[October 2024]

Bidders to submit at the time of Tender completed Schedule of Rates for items in Annex B to be utilised on approval by the Engineer for Unforeseen Cases. The unit rates for Civil Works and Dayworks should be competitive. *(The engineer may choose to use these rates or source for competitive rates prevailing at the time)*

- (xxiii). Provide and maintain in serviceable condition, **1 No. 4x4 double cab pickup of 2400cc - 2800cc engine capacity (odometer: 0 - 100,000 km in a bid to manage costs for chase cars) at Webuye weighbridge, fully fitted with a tracking device and bulbar as chase cars.** The provision and maintenance of this item will be approved and monitored by the Engineer. The cost meeting this requirement will be provided for by the contractor in his rates for weighbridge operations and maintenance and **no separate payment will be provided.**
- (xxiv). Provide including driver, fuel, service and maintain vehicles for the exclusive use of the Engineer in accordance with Clause 138 of the Standard and Special Specifications. The vehicles shall revert to the Contractor at the end of the contract.
- (xxv). The Management Contractor shall deploy all the required staff to the Weighbridges as per Appendix A for the efficient operations at the Weighbridges throughout the Contract Period. The **Remuneration Levels of the above staff** shall be enforced during the Contract implementation. *The Contractor shall be required to provide evidence of compliance through payslips and statutory deductions where compliance is in doubt.* The Contractor Shall deploy all required staff before the start of the Shadowing Period. **No separate payment will be provided to comply with this requirement.**

*Note: Abnormally low rates as well as abnormally high rates in this regard may lead to the invocation of the Clauses 29 and 30 of the Instructions to tenderers during the evaluation process. Bidders are therefore advised to provide competitive rates for staff remunerations.*

- (xxvi). Operation and Maintenance of 2 No. Mobile Weighbridge units for adjacent road network monitoring. **The Engineer shall be facilitated by the Management Contractor to have unlimited Access to the live data and location of the mobile teams at all times. A daily mobile network monitoring for each team shall weigh not less than 50 vehicles and cover a network not less than 150 kilometres.** Other than the daily 24-hour mobile monitoring, the contractor shall carry out an intensive ten (10) day enforcement operation every quarter to clear any pockets of non – compliant networks within their cluster in consultation with the Engineer. **The Contractor shall include in his rates all costs for the mobile operations under his network including staff night outs and overtimes. Where a quarterly 10 day intensive enforcement operation has not been conducted in the due quarter, a recovery in the quantum of KShs 1,000,000 (One Million Kenya Shillings) shall be made from the Interim Payment Certificate (IPC) of the subsequent quarter to ensure compliance with this provision. This will be instrumental in dealing with resistance in some parts of cluster(s) which may develop such tendencies. This penalty shall be doubled where there is failure for the second and subsequent quarters and shall not be recoverable by the Contractor whatsoever for the forgone service.**
- (xxvii). Provide for and maintain two mobile teams on a 24-hour basis, equipped with 2 No. Brand New 4x4 double cab pickups fitted with a web-based tracking device and a strong bull bar on the front and the rear for managing and monitoring the road network. The provision of this will be approved and monitored by the Client. Daily and Periodic reports will be submitted to the Engineer. **The frequency to be covered by the Mobile weighbridge teams for the adjacent 2073 km road network in a month is as follows;**

[October 2024]

**Mobile Weighbridge Patrol Frequency**

No	From	To	Road Class	Length in Km	Frequency	Total Length
1	Kakamega - Webuye-Kitale	Lodwar - Nadapal-Lokitaung	A1	451.80	5	2259.00
2	Malaba-Webuye	Webuye – Mau summit	A8	138.99	5	694.94
3	Lokichar	Amosing	A10	31.00	5	155.00
4	Jnct A1[Makutano]	Kaaling	B117	18.20	5	91.00
5	Eldoret	Kapsabet	B8	40.20	5	201.00
6	Kakamega-Ekero-Chepsonoi-Kapsabet	Chebarbar-Lessos-Nabkoi	B12	154.60	5	773.00
7	Chemolingot-Barpello	Marigat-Loruk	B17	85.10	5	425.50
8	Kapcherop	Naiberi - Kapchorwa	B122	126.40	5	632.00
9	Cheptiret	Kimondi	B123	13.60	5	68.00
10	Eldoret - Nyaru	Kapkayo - Tenges	B124	41.00	5	205.00
11	Kapsokwony-Namwela-Sirisia	Malaba-Busia	B13	97.90	5	489.50
12	Chemelil	Muhoroni-Fort Tenan	B132	116.31	5	581.57
13	Bungoma-Namakoye-Kakamega	Mungatsi-Bungoma	B137	72.07	5	360.37
14	Mayoni-Bungoma	Mayoni-Bungoma	B139	27.00	5	135.00
15	Maili Tisa	Kitale	B14	55.00	5	275.00
16	Ebuyangu	Ekero	B140	30.00	5	150.00
17	Malakisi-Lwakhakha	Mungatsi-Malakisi	B141	42.06	5	210.30
18	Bungoma-Chwele	Namwela-Kamukuywa	B142	52.50	5	262.50
19	Marigat-Kabarnet-Iten	Kachibora- Sibanga-Kitale	B15	117.00	5	585.00
20	Loima	Lodwar A	B70	12.00	5	60.00
21	Lokichogio	Lokitaung(A)	B71	5.00	5	25.00
22	Lodwar	Kalokol	B72	56.90	5	284.50
23	Kapenguria	Konyao	B70	80.00	5	400.00
24	Kamwosor-Nyaru-Iten	Chebiemit-Kamatira	B77	207.90	5	1039.50
<b>TOTAL</b>				<b>2073.00</b>		<b>10363</b>

(xxviii) The operational (mobiles, chase and cluster managers) cars shall be fitted with **dash cams with the following specifications;**

**4 Channel Camera**

Features:

- i. 4/5 Channel Recording
- ii. Video Surveillance
- iii. Clip and Event Alerts
- iv. Driver Fatigue/Distraction Monitoring (DMS)
- v. Advanced Driver Assistance (ADAS)
- vi. Critical Video to Cloud
- vii. Audio recording

[October 2024]

Specifications:

- i. Front Camera (Main) - 1920×1080/25FPS/F2.0/Full color/80° (HFoV)
- ii. Sub Camera - 1280×720/15FPS/F2.5/Full color in daytime & monochrome in dim light/135° (HFoV)
- iii. Peripheral Camera
- iv. CI01: 1280×720/15FPS/F2.0/Full color in daytime & monochrome in dim light/100° (HFoV)
- v. CI03: 1280×720/15FPS/F2.4/Full color in daytime & monochrome in dim light/119° (HFoV)
- vi. CD02: 1280×720/15FPS/F2.0/Monochrome/56° (HFoV)
- vii. CE01: 1280×720/15FPS/F2.0/Full color/IP67/125° (HFoV)
- viii. Extended Memory Card Support up to 512GB

*Where the dash cams are not provided in accordance with this requirement, a penalty in the quantum of KShs 100,000 (Kenya Shillings One Hundred Thousand) per day shall be made till compliance is achieved.*

## 5.5 ASSUMPTIONS & RISKS

### 5.5.1 Assumptions underlying the contracting

In order to achieve the purpose of this contract, the Client will make available funds for running the contract through the Fuel Levy Fund.

It is expected that the Contractor will ensure that the services are properly carried out in accordance with this TOR. Traffic regulations will have to be enforced, in so far as axle loads are concerned. The recommendations on improving road safety and mitigating environmental impact shall be implemented.

### 5.5.2 Risks

There are no major risks anticipated on the carrying out of the contract. The extension of controls on axle loads to the whole network is envisaged through the use of both static and mobile units spread across the KeNHA network of roads (Class S, A and B roads).

## 5.6 SCOPE OF THE WORK

### 5.6.1 General

The Contractor shall conscientiously fulfil, to the highest professional standards, the role of managing the weighbridge station and to ensure that the assignment is carried out to the highest ethical standards in accordance with the Conditions of Contract, or any amendments thereto, and within the Contract Price.

The contract services detailed in this document are for operations, management and maintenance of the weighbridge stations, calibrations of the equipment including repairs and replacement of parts for mobile scale, single axle, and multi axle and weighing-in-motion scales.

### 5.6.2 Management, Operations and Maintenance of Webuye Weighbridge Stations and 2073 Km Adjacent Road Network.

Webuye Weighbridge Station is situated along Eldoret – Malaba highway at Webuye along A8 road.

[October 2024]

Facilities at the stations include offices, High Speed Weigh in Motion systems, CCTV cameras, Automatic Number Plate Recognition cameras, automatic traffic data logging equipment, traffic management equipment, multi deck scales, mobile scales and accessories.

The Weighbridges are operating on Kenload Version 2 Weighbridge Management System. The System is Integrated with all the Static and Virtual Weighbridges. The Contractor shall make prior arrangements on Training of his staff prior to Contract Commencement date on the use of Weighbridge Management Software for smooth operations once he takes over.

### 5.6.2.1 Installation and maintenance of Communications and data recording facilities

#### 5.6.2.1.1 Communications and Weighbridge Control Centre

The Contractor shall maintain and facilitate: -

- (a) All valuable assets on the premises continuously,
- (b) Vehicle progress through facility,
- (c) Staff activity relating to weighing and prosecution processes.

The present equipment set-up as they are shall be repaired and/or replaced and/or calibrated so as to function optimally.

The Weighbridge stations shall serve as the control centres of operations of Axle Load Control facilities where the Weighbridge manager will:

- (a) Monitor and control normal operations.
- (b) Ensure a vehicle is intercepted (in the case a vehicle transgresses or ignores instructions from control centre) within the network under its jurisdiction.
- (c) Monitor the integrity of communication links and implement alternative operations procedures when communication links are down.
- (d) Initiate maintenance and intervention procedures.
- (e) Only authorized personnel will have access to designated areas/equipment and Contractor shall design and implement access control for each operator or officer.
- (f) While on duty at the weighbridges, **ALL Weighbridge Staff and Police Officers** will not be allowed to have their private **mobile phones**. All phones shall be surrendered in one central location to be collected after duty. **ALL Weighbridge Staff and Police Officers on mobile operations SHALL not carry mobile phones while on the operations. Police officers and staff shall only use official office lines to be provided by the contractor while on duty for both static and mobile operations. Where a staff or a Police officer is found in possession of phones contrary to the requirement of this clause, a monthly salary for the staff/allowance in case of a police officer shall not be paid in the first instance. A subsequent occurrence of the same by the staff/police officer shall lead to dismissal of the staff/officer from the service at weighbridge and the staff/officer shall forthwith not be engaged in any of the Authority's Weighbridge installations in any capacity.**
- (g) To enhance integrity, **ALL Weighbridge staff/officers while on duty must be in clearly identifiable uniforms and name tags at all times. Where this requirement has not been complied with, a penalty of KSh 50,000 (Fifty Thousand Kenya Shillings) shall be recovered from the Contractor in the next Interim Payment Certificate falling due. A repeat of the occurrence on such staff shall attract a penalty of double the amount. Use of KeNHA and National Police Service Logos Shall only be allowed with the Approval from the Engineer.**



[October 2024]

#### 5.6.2.1.2 Man Machine Interfaces

A standard full and operational Desktop Computer terminal will be necessary for this engagement. It is recommended that the following officers be equipped with a computer;

- (a) Control Room – 2No for the Manager and Systems Administrator.
- (b) Scale Operator – 1 No (with the required redundancy)

Where the facilities do not exist, the Contractor shall provide for their inclusion as a minimum in its other rates and shall be supplied upon the instruction of the Engineer.

Weighing operator terminals shall be maintained and used **at all times** in weighing and in issuing weighbridge tickets ONLY. **The Contractor is required to retain redundant systems/equipment on site for use in the event of a breakdown.** Such equipment must be identifiable on site and available for inspection at all times.

#### 5.6.2.2 Transgression Records

Transgression records shall be kept for the following offences, and transmitted in the format required by prosecuting authorities:

- (a) Overloaded vehicle in terms of Gross Weight and Axle load/axle group limits as provided in the Traffic Laws of Kenya
- (b) Absconding/bypassing of the weighbridge
- (c) Disobeying traffic law enforcement personnel
- (d) Previous records of transgression

#### 5.6.2.3 Specific activities

The task to be carried out by the Contractor will call for the services listed below, without, however, being necessarily and restricted to the items identified:

##### **Phase 1: Taking over the facilities/mobilisation**

- Inspection of the existing facilities
- **Carry out an inventory of all existing equipment's and submit to the Engineer**
- Familiarisation with the operations of the weighbridge station
- Checking the existing physical infrastructure
- Checking existing computer hardware and software
- Reviewing the existing operations and making proposals for modification in the operational details which may be reasonable and preparing the required amendments to the relevant documents with prior approval by the Employer.
- Assessment of the implications of the reviews to the cost of the contract; and
- Preparation of a reviewed and updated operations manual and submitting the same to the Engineer for approval.

##### **Phase 2: Operations management**

- Preparation of a daily work programme and monitoring, adherence to this programme
- Regularly Maintain and operate the mobile weighbridge units
- Directing, with police assistance and depending on state of weighbridge automation, the vehicles to the weighbridge station for weighing by axle, group Axles and Gross Vehicle Weights.
- Transmission of the axle load data to the Employer electronically.
- Analysis of the axle-load data collected
- Regular Calibration of the weighing scales after **every three (3) months** or whenever repairs are carried out, whichever occurs first. ***This shall be done by the Weights and Measures***

[October 2024]

*Department. A Certificate of Calibration shall then be issued to the Client after every calibration exercise.*

- Compilation of analysed data and submission of a summarised daily and weekly report to the Engineer.
- Production of periodic monthly, quarterly, annual and final reports on the operation of the weighbridge cluster
- Advising the Employer, regularly, on problems arising during the carrying out of the contract.
- Ensuring efficient use of resources and protection of the environment.
- Requesting for and carrying out HIV/AIDS awareness campaigns in liaison with the responsible Ministry of Health
- Organising for regular meetings in consultation with the Engineer with stakeholders such as drivers, transporters, cargo owners and cargo generation points to disseminate information about overloading and
- Coordination with third parties, e.g. Public Utilities, Traffic Police.

## **5.7 DETAILED DESCRIPTION OF THE SERVICES**

### **5.7.1 Phase 1: Taking over the facilities/mobilisation**

The services shall be rendered concurrently during the initial 1 month of start of Contracting Services, which may be extended by a further one (1) month. The Contractor shall receive all available data from the Engineer and shall supplement non-available data for checking and reviewing before submitting the same to the Engineer for approval.

The Contractor will be deemed to have acquainted himself with the Management Contract Document.

### **5.7.2 Phase 2: Operations Management**

#### **5.7.2.1 Preparation of a daily work programme and monitoring, adherence to this programme**

The Contractor will **review the measures for traffic management with respect to traffic diversions and passage of traffic through the weighbridge to ensure minimal disruption of normal traffic flows** and further to ensure that the measures will in no case compromise the safety of all the road users.

The Contractor will be responsible for identifying those items requiring the approval of the Engineer and bring these items to his attention for action.

As much as the prevailing circumstances will dictate, the Contractor shall organise monthly site management meetings with the concurrence of the Engineer.

The Contractor shall ensure that an adequate record of data is kept for the purpose of establishing an accurate databank. The Contractor shall share operations data with management contractors' adjacent weighbridges clusters to facilitate smooth and seamless operations within the Authority's Road networks.

#### **5.7.2.2 Weighing Operation.**

Only a single vehicle is allowed into the weighing area/scale at a time. The process is initiated (depending on the level of weighbridge automation) by the weighbridge operator. Where high speed weigh in motion is available, the weighing operation will start with the vehicle going over the weigh in motion equipment to determine whether it is diverted for static weighing or not. At the static scale (on the part of the contractor), the computer operator weigher (cow) shall initiate the process by recording the vehicle registration number (or confirm the correctness of the automatic number plate recognition camera entry) in the system thus creating a new record of the vehicle.

[October 2024]

A public address (PA) system allowing one-way communication from the scale operator to the truck driver exist at every static scale and has to be maintained. The contractor should ensure that all windows and doors are closed to eliminate any contact between the machine attendant (cow) and transport crew. If all the axles of the truck are within legal limits, the record is closed, the driver issued with a weighbridge ticket and the vehicle allowed access back to the road, by announcing over the PA or automatically opening the exit boom gate.

The Employer may institute random checks anywhere en-route for vehicles weighed by the contractor. **The Management Contractor shall be surcharged an amount equivalent to five times the applicable fine/or overload fee of the overload as prescribed in the EACVLC Act, 2016 or the Traffic Act if any vehicle is impounded with overload after passing a static weighbridge under his/her management. (Due diligence will be ensured before arriving at this surcharge)**

If the truck has one or more overloaded axles the driver is informed that the truck is overloaded and that it has been impounded and is escorted to the holding yard. The driver is instructed to return to the office after the parking the truck where s/he shall be required to produce his/her details to the duty Police Officer for the prosecution process to commence. A vehicle that has been detected as overloaded is issued with a Prohibition Order and is subsequently prosecuted for the offence. On completion of the prosecution process and off-loading or re-distributing as the case may be, the truck will be allowed further passes through the weighing process (until none of the axles are overloaded beyond allowable tolerance) without further prosecution.

Lane transgression records will be compiled by contractor. **If a driver does not adhere to the road signs and carries on driving along the main carriageway, a camera will take a picture of the truck (automatic tagging).** Lane transgression records will be passed on to the Police for enforcement.

**The computerised system must be set such that the operator cannot override the system to let an overloaded vehicle back onto the road.**

**A relief vehicle (truck sent to share the load of an overloaded truck) will gain access to the holding yard via the same approach as all the other trucks and will be subjected to the same weighing process.** The trucks from the holding yard join the queue at the entrance to the weighbridge when they are ready to be weighed, check/confirm again.

Records are backed-up from the server and sent to a central overload control centre at the Kenya National Highways Authority headquarters in Nairobi. The deployment will use suitable automatic data transfer system via a permanent communications channel between the central overload control centre and the weighbridge station.

### 5.7.2.3 Dynamic Operation of the Overload Control System

The weighing station will be operated for 24 hours per day. In order to achieve optimum efficiency, the intensity of operation of the weigh stations should be variable i.e. it should be able to accommodate sufficient personnel for peak period operations, or operate fewer streams if volumes are considered too low to warrant full operation. However, the contractor must at all times maintain the minimum critical staff level as in the schedule.

### 5.7.2.4 Personnel Access Control System

Access to buildings and the system's facilities will be centrally controlled by the Contractor including biometric system. Personnel will be issued with an identification mechanism that cannot be duplicated and which shall not be transferable.

[October 2024]

The weighing room must be secured at all times with automatic door closures. Only authorised personnel should enter the weighing room.

A separate room must be maintained for documentation of prosecuted cases.

### **5.7.3 Advising the Employer on problems arising during the carrying out of the contract**

The Contractor shall compile **Monthly Management Reports** to inform all parties concerned in a transparent and concise way about the progress of the operations and management services, including difficulties and challenges encountered. On completion of every 3 months, the Contractor shall prepare **Quarterly Management Reports**. At the end of every calendar year, an **annual report** will be prepared. Finally, at the end of the contract, the final report covering the whole contract period, in a summary form, will be prepared.

The Contractor shall maintain documentary and photographic records. Cameras have been provided to the Officer Commanding Police Stations at the Weighbridges for capturing and processing Photographic evidence during Mobile operations which should be certified by scene of crime before presentation to courts. The documentary records shall include a Daily Site Diary and details of all contractual correspondence and data; all work stoppages or delays; accidents on site; official visitors to site; weather records; details of all daily site activities showing the start and end time and full details, or the personnel and equipment resources employed per activity. It shall contain detailed records of the contractor's equipment on site and its date of manufacture, previous hours worked and condition, its precise date of arrival or removal from site, the date commissioned to commence work, its availability and utilisation. Equipment availability figures for each category of equipment shall be established.

In respect of photographic data, the Contractor shall maintain a record of digital photographs (issued to the OCS) of contractual interest taken at any time throughout the Contract period. Each photograph is to be captioned with; reference number, time, date, precise location, subject and points of particular note. These digital data shall be stored on a CD-ROM together with the captions and shall be made available to the Engineer on a monthly basis. The photos will also be uploaded into the clients' server.

**The Contractor in liaison with the National Police Service, shall ensure all records at the weighbridges are digitized including the case files and backed up in the Authority Servers.**

### **5.7.4 Advice on problems arising during the execution of the Management Contract**

In the event problems arise during the execution of the management contract, the Contractor will address these problems and suggest solutions. These problems should be subject to a special report to the Engineer, who will decide whether they are analysed on site by the Contractor or referred to other competent bodies. The Contractor shall not be requested to deal with problems regarding land acquisition, right of way and damage to third party property and shall only play a coordinating role with respect to problems regarding public utilities and traffic management.

### **5.7.5 Monitoring of sound use of resources and protection of the environment**

The Contractor shall monitor human and material resources mobilised by it and keep a comprehensive record of these resources and the use made thereof. In his periodic reporting the

[October 2024]

Contractor shall relate resources mobilised and works performed. Unbalanced resources or discrepancies between projected outputs will be brought to the attention of the Engineer.

#### **5.7.6 Coordination with third parties**

The Contractor shall ensure that all stakeholders affected by weighbridge operations are informed about the developments on site relevant to their respective competencies. Representatives of public utility firms, Traffic Police, local government, water management bodies and other Non-Governmental Organizations shall be invited from time to time to site whenever necessary to hold special coordination meetings.

### **5.8 PROJECT MANAGEMENT, CONTRACTUAL FRAMEWORK AND RESPONSIBILITIES**

- 5.8.1** The Employer for the Management Contract will be the Director General, Kenya National Highways Authority (KeNHA). The Employer's officials will be the Director, Maintenance as the Engineer and the Deputy Director, Axle Load Control as the Engineer's Representative.
- 5.8.2** The Deputy Director, Axle Load Control will be the Representative of the Director, Maintenance for all the weighbridge functions during the contract period.
- 5.8.3** Responsibilities that the Engineer will retain with respect to the works contract will include all legal and financial issues arising from claims and disputes by third parties relating to land tenure, national planning, damage caused to commercial interests and issues of similar nature. The Engineer will also retain the responsibilities for the project budget and the management of the financial allocations to the contracts, conclusion of these contracts, issuing of commencement orders, variation orders and responsibilities for dispute resolution in consultation with the Kenya Chapter of the Chartered Institute of Arbitrators of Kenya.
- 5.8.4** The Engineer's Representative will facilitate decision making in matters pertaining to the Management Contract that are either not covered by the delegation of powers to the Contractor or that need a decision by the Engineer once the Contractor has fulfilled all his obligations under these Terms of Reference.
- 5.8.5** The Engineer's Representative will be the Contractor's day-to-day contact person in the Authority. The Contractor will keep the Engineers Representative informed in a detailed way of all developments on site. The Engineer's Representative will visit the site regularly and will assist in all site meetings.

### **5.9 LOGISTICS AND TIMING**

#### **5.9.1 Project Location:**

The services will be provided at Webuye Weighbridge Station and two mobile units operated to enforce Overload Control along the following routes on an agreed monthly program to be submitted to the Engineer to ensure compliance with the EAC Vehicle Load Control Act, 2016 and the Traffic Act among other Acts across the network.

[Request for Proposals for Webuye Weighbridge Station and the 2073 KM Adjacent Road Network]

[October 2024]

No	From	To	Road Class	Approximate Road Length (Km)
1.	Kakamega - Webuye-Kitale	Lodwar - Nadapal-Lokitaung	A1	451.80
2.	Malaba-Webuye	Webuye – Mau Summit	A8	138.99
3.	Lokichar	Amosing	A10	31.00
4.	Jnct A1[Makutano]	Kaaling	B117	18.20
5.	Eldoret	Kapsabet	B8	40.20
6.	Kakamega-Ekero-Chepsonoi-Kapsabet	Chebarbar-Lessos-Nabkoi	B12	154.60
7.	Chemolingot-Barpello	Marigat-Loruk	B17	85.10
8.	Kapcherop	Naiberi - Kapchorwa	B122	126.40
9.	Cheptiret	Kimondi	B123	13.60
10.	Eldoret - Nyaru	Kapkayo - Tenges	B124	41.00
11.	Kapsokwony-Namwela-Sirisia	Malaba-Busia	B13	97.90
12.	Chemelil	Muhoroni-Fort Tenan	B132	116.31
13.	Bungoma-Namakoye-Kakamega	Mungatsi-Bungoma	B137	72.07
14.	Mayoni-Bungoma	Mayoni-Bungoma	B139	27.00
15.	Maili Tisa	Kitale	B14	55.00
16.	Ebuyangu	Ekero	B140	30.00
17.	Malakisi-Lwakhakha	Mungatsi-Malakisi	B141	42.06
18.	Bungoma-Chwele	Namwela-Kamukuywa	B142	52.50
19.	Marigat-Kabarnet-Iten	Kachibora- Sibanga- Kitale	B15	117.00
20.	Loima	Lodwar A	B70	12.00
21.	Lokichogio	Lokitaung(A)	B71	5.00
22.	Lodwar	Kalokol	B72	56.90
23.	Kapenguria	Konyao	B70	80.00
24.	Kamwosor-Nyaru-Iten	Chebiemit-Kamatira	B77	207.90
<b>TOTAL</b>				<b>2073</b>

The mobile units shall be fitted with web-based vehicle tracking system to monitor their movement in real-time giving the location, and activities as they are. Any weighing operations conducted by the mobile unit while the tracking device is switched off shall not be included in the monthly submissions for payments. The weighing records should be uploaded to the server in real time.

Records must be available to the Employer as part of the daily, weekly and monthly reports. Further access to the live data on the location of the mobile teams must be granted to 2No representatives of the Employer.

### 5.9.2 Project Period:

**The Contract period shall be 28 months, including; -**

Phase 1: Taking over the facilities.

Phase 2: Operations management – 27 months.

Phase 3: Finalising Operations and Handing over – 1 month.

[October 2024]

## 5.10 REQUIREMENTS

The contractor shall be deemed to have inspected the work sites and availed himself all pertinent information before submitting a proposal and the full and comprehensive cost for management, maintenance and operation of the weighbridge cluster for a period of Twenty-Eight (28) months shall be deemed included in the contractor's price proposal.

### 5.10.1 STAFF REQUIRED

**For guidance purposes only, the estimated minimum number of Key Staff** required for operating the three weighbridges and the **2073 Km** Adjacent Road network (including operating two mobile weighbridges on full time basis) are as follows: -

#### 1) Head Office Management

For effective Cluster administration the contractor will have to maintain and staff a head office team comprising but not limited to the following;

S.NO	STAFF	NO.
1	Operations Manager	1
2	Technical Manager	1

**Where a Bidder is awarded more than one Contract, He/she shall additionally recruit an Assistant Operations Manager with similar qualifications as the Operations Manager for effective superintendence of the contracts**

The qualification of key headquarter staff shall be as outlined below

All site staff except Weighbridges Cluster Manager shall be engaged in a shift not exceeding 12 hours and in adherence to labours laws

- (a) Weighbridges Cluster Manager
- (b) Assistant Weighbridge Manager (Static Stations) – 1 per bound per shift for bigger stations but one per station for smaller stations
- (c) Assistant Weighbridge Manager (Mobile Operations) – 1 per mobile unit per shift
- (d) Control Room operators/ Systems Administrator- 1 per weighbridge station per shift
- (e) Operations and Maintenance Technician (Electrical) - 1 per station, standby fulltime
- (f) Operations and Maintenance technician (Electromechanical) - 1 per station, standby fulltime
- (g) Vehicle Inspectors - 1 per bound per shift
- (h) Computer Operators weighing - 1per scale per shift
- (i) Computer Operator Prosecution - 1per scale per shift
- (j) Vehicle Inspectors - 1 per bound per shift
- (k) General Assistant- 1 per scale per shift and 1 to assist each Vehicle Inspector for taking vehicle measurements
- (l) Security Guards – Adequate for all Key stations i.e Entry, Exits, HSWIM Equipment gantry, Yards etc on 24-hour basis.

**Note: The numbers indicated above are the minimum staff requirement and does not limit the contractor from deploying additional staff with specified qualifications for the role for effective weighing at the weighbridge stations especially during the peak hours. The**

[October 2024]

**contractor shall bear the costs for additional staff other than those provided under Appendix A for his/her effective management of operations and maintenance. *The Contractor SHALL not engage in his employment under this Contract, any persons who have been dismissed from the service of the Weighbridges on account of integrity of the individual staff.***

In addition, four (4-No) Police Officers will be required per shift for enforcement at the static scale; i.e., two at the diversion and two attending the weighbridges whereas Two (2No) Police Officers will be deployed to each mobile team whenever they are in operations per shift. 2 police officers will be required whenever needed for approach to the High-Speed Weigh in Motion (HSWIM) and also to ensure smooth flow of traffic. The contractor will be required to pay subsistence allowances to Police Officers at the rates as scheduled in the Police Allowances item in the Bills of Quantities.

The guide for minimum staff requirement and qualification does not preclude the contractor from employing the latest technology in ensuring that traffic is diverted and weighed as per the Traffic Act and the East African Community Vehicle Control Act, 2016.

The profiles of the key staff to be provided by the Contractor for this Management Contract are as follows:-

Qualification of Key site staff

#### **Site Staff 1: Weighbridges Cluster Manager**

##### **Key Qualifications**

- The Staff proposed as Weighbridges Cluster Manager must possess a Bachelor's Degree from a recognized University.
- A minimum of (5) years in a management role in comparable position in the Public Service or in the Private Sector preferably.
- The candidate should be of high integrity (provide a current certificate of good conduct).
- He must be well versed with the Laws of Kenya, especially, the Penal Code, the Civil Procedure Code, Company Law, Public Roads Act and the Traffic Act (CAP 403) of the Laws of Kenya and related amendments and the East African Community Vehicle Control Act, 2016 (EACVLC) and its attendant Regulations.
- Certificate in Management Course lasting not less than four (4) weeks from a recognized institution.
- Proficiency in computer applications.
- Fulfilled the requirements of Chapter Six of the Constitution.
- Valid Annual Practicing License from recognized professional body.

##### **Detailed Tasks Assigned**

- He/she shall assist in the Management, Operation and Maintenance all the weighbridge station facilities in line with the Terms of Reference (TOR) and the general conditions of the contract.
- He/she shall oversee the day-to-day operations of all the weighbridge stations in the cluster including mobile operations.
- Supervise all Contractor's Staff assigned to the Weighbridge Stations in the cluster.
- In liaison with the Operations Manager, continuously engage with the Courts through organized cluster retreats, CUCs, visits to individual Courts, Periodic Stakeholders Meetings,



[October 2024]

Media Communication Sensitization, drivers, transporters and other stakeholders on compliance with axle load limits.

- In liaison with the Operations Manager, coordinate with other government agencies such as the Courts, KRA, KPA, NTSA, EACC, NPS during the execution of the Contract.
- Enforce axle load limits in close liaison with the Virtual Weighbridge Stations, Mobile teams and the Axle Load Enforcement Highway Unit (ALEHU).
- Report to the Operations Manager on all weighbridge operational matters.
- Conduct regular patrol the cluster network at least 3 days per week to monitor mobile operations and gather information critical for enhancing compliance throughout the entire cluster network.

#### **Site Staff 2: Assistant Weighbridge Manager**

- The staff proposed for the position of Assistant Weighbridge Manager shall possess a Higher National Diploma from a recognised University.
- He/she shall have three (3) years proven experience in Business Administration, have good communication skills and be of high integrity.
- In addition, he/she shall have adequate experience and exposure to Public or Private sector administration and knowledge of and experience in administration of a technical facility/project in a similar position.
- Proficiency in computer applications.

#### **Detailed Tasks Assigned**

- Assist the Weighbridge Cluster Manager in the overall management of the weighbridge activities to include planning / scheduling of key operations / activities.
- Supervision of all Shift staff and ensure optimal operations at the static stations.
- Carry out Mobile Weighbridge Operations.
- Ensure that all clients that visit the station are received and their matters addressed as per the clients' expectations and escalate any matter beyond their intervention to the CM.
- Ensure that weighbridge equipment and facilities are well kept and maintained on a daily basis and their maintenance records are properly filled, signed and filed accordingly by relevant staff.
- Attending court matters, if need be, in line with their work.
- Enforce operational processes and procedures as defined as per the staffs' roles.
- Coordinate shift operations with the help of the Officer Commanding the Weighbridge Police Station.
- Perform any other duties as will be assigned from time to time.

#### **Site Staff 3: Systems Administrator/Control Room Systems Operators**

- The Staff proposed as Systems Administrator/Control Room Systems must possess a Bachelor of Science degree or Diploma in any of the following fields; Computer Science, Information systems, Information Technology, Business & IT or Computer Engineering.
- In addition, he/she should possess at least a Certified Network Associate qualification (or equivalent) with three (3) years hand-on experience in Network Administration or Systems Integration in a busy database management environment.
- He/she should have proven knowledge on enterprise databases and computer applications
- Fulfilled the requirements of Chapter Six of the Constitution.

#### **Detailed Tasks Assigned**

- Effectively Manage systems operations to ensure continuity of weighing
- Daily Data backup and recovery.

[October 2024]

- Installing and configuring software, hardware, and network devices.
- Monitoring system performance and troubleshooting.
- Ensuring security and efficiency of IT infrastructure, anti-viruses and window licenses are in proper good working state both for the servers and the normal PC/Desktops.
- Systems installation, fault reporting and system monitoring to ensure availability throughout the operating cycle.
- Ensure that the machines are properly maintained on a daily/weekly/monthly/quarterly basis as defined in their maintenance schedules and that all the computers at the station are in proper and good working condition.
- Support the operations teams during working hours.
- Ensure uninterruptable data capture, storage, archiving and dissemination.
- Diagnose and resolve technical hardware and software issues.
- Supervision and training systems users.
- Prepare and maintain schedule of preventive maintenance for all IT infrastructure.
- Undertake other IT duties as assigned.

#### **Site Staff 4: Certified Technicians (Electrical)**

- The Staff proposed as a Certified Technician (Computer Science/Information Technology (IT)/Software Engineers) must possess a minimum qualification of a Diploma in any of the following fields; Information Technology, Computer Science, or Computer Engineering and Software Engineering attributes from a recognized institution.
- A minimum of at least three (3) years hands-on experience as a Technician preferably in activities related to weights and measurements.
- The candidate should be of high integrity (provide a current certificate of good conduct).
- Proficiency in computer applications.
- Fulfilled the requirements of Chapter Six of the Constitution.
- Valid Annual Practicing License from recognized professional body.

#### **Detailed Tasks Assigned**

- Maintenance of weighbridge IT equipment and infrastructure for Business continuity.
- Remote trouble shooting of both hardware and software problems.
- Installation Computer software, upgrade and monitoring of computer-controlled weighing systems.
- They may also be involved in calibration and networking of electromechanical systems hardware and software and mid-range server hardware.
- Assist in calibration of the weighbridge stations.
- Networking of electromechanical systems hardware, software and servers.

#### **Site Staff 5: Certified Technicians (Electro-Mechanical)**

- The Staff proposed as a Certified Technician (Electro-mechanical) must possess a minimum qualification of a Diploma in any of the following fields; Electrical and Electronics Engineering, Mechatronic Engineer, Electrical Engineering, Systems Engineering, , Electrical & Communications Engineering, Bachelor of Technology (Electronics & Systems), Bachelor of Technology (Instrumentation & Control), Information Technology, Computer Science, or Computer Engineering from a recognized institution.
- A minimum of at least three (3) years hands-on experience as a Technician preferably in activities related to weights and measurements.
- Has Certificate of Competence from Weights and Measures Department to carry out repairs to Type 3 electronic weighing equipment.
- The candidate should be of high integrity (provide a current certificate of good conduct).

[October 2024]

- Proficiency in computer applications.
- Fulfilled the requirements of Chapter Six of the Constitution.
- Valid Annual Practicing License from recognized professional body.

#### **Detailed Tasks Assigned**

- Maintenance of weighbridge equipment and infrastructure for Business continuity.
- Remote trouble shooting of both hardware and software problems.
- Installation, upgrade and monitoring of weighing systems.
- Assist in calibration of the weighbridge equipment.
- Networking of electromechanical systems hardware, software and servers.

#### **Site Staff 6: Vehicle Inspector.**

- The Staff proposed as a Vehicle Inspector must possess a diploma in Mechanical Engineering Automotive Option.
- He/she must have three years (3) hands-on experience in vehicle inspection and determination of compliance of a vehicle with the requirements of the government Vehicle Inspection Unit.
- He/she should have a basic understanding of the Traffic Act (CAP 403) of the Laws of Kenya and related amendments and the East African Community Vehicle Control Act, 2016 (EACVLCA) and its attendant Regulations more so on vehicle axle configurations.
- Proficiency in computer applications.
- Fulfilled the requirements of Chapter Six of the Constitution.

#### **Detailed Tasks Assigned**

- Carryout vehicle inspection to verify the Exemption Permit Conditions and Guidelines
- Inspect the lift and dummy axles of vehicle for correct axle weighing.
- Safety check of all heavy vehicles Impounded at the weighbridge.
- Check on certificate of roadworthiness.
- Check on hazardous chemicals.
- Check on insecure load.
- Check on vehicle mechanical defects.
- Check on failure to comply with abnormal load permit.
- Check on vehicle insurance.
- Check on First Aid Kit.
- Check on vehicle mechanical defects.
- Ensure that the wide loads/oversized cargo trucks are inspected, verified and weighed as per the applicable axle load laws and regulations with the help of the police officers.
- Attend court on matters inspection of non-compliant vehicles.
- Maintain a log of all vehicles checked in the check forms.

#### **Site Staff 7: Computer Operator Weighing**

- The Staff proposed as a Computer Operator Weighing must possess a Diploma in any of the following fields; Information Technology/ Computer Science, Business & IT or Computer Engineering qualification or be in possession of the International Computer Driver's Licence (ICDL) certification.
- The staff must have three years (3) hands-on experience as computer terminal operator in a busy data processing environment or equivalent.
- He/she should have a basic understanding of the Traffic Act (CAP 403) of the Laws of Kenya and related amendments and the East African Community Vehicle Control Act, 2016 (EACVLCA) and its attendant Regulations.
- Proficiency in computer applications.

[October 2024]

- Fulfilled the requirements of Chapter Six of the Constitution.

#### **Detailed Tasks Assigned**

- Accurately weigh the vehicles that come to the scale for weighing.
- Ensure proper axle positioning before assigning the weight.
- Ensure that the correct configuration details of the trucks are taken, especially those that are charged and liable to prosecution.
- Ensure that the trucks sent to the yard for redistribution/weight correction are properly re-weighed before they are issued with compliance certificate.
- While working at the directing office, communicate with Traffic Police Officers in cases where trucks do not divert to weighbridge as instructed by the System.
- Check legal status for weighed vehicles and give accurate information to Drivers and General Assistant.
- Perform any other duties as will be assigned from time to time.

#### **Site Staff 8: Computer Operator Prosecution**

- The Staff proposed as a Computer Operator Prosecution must possess a Diploma in any of the following fields; Information Technology/ Computer Science, Business & IT or Computer Engineering qualification or be in possession of the International Computer Driver's Licence (ICDL) certification.
- The staff must have three years (3) hands-on experience as computer terminal operator in a busy data processing environment or equivalent.
- He/she should have a basic understanding of the Traffic Act (CAP 403) of the Laws of Kenya and related amendments and the East African Community Vehicle Control Act, 2016 (EACVLCA) and its attendant Regulations.
- Proficiency in computer applications.
- Fulfilled the requirements of Chapter Six of the Constitution.

#### **Detailed Tasks Assigned**

- Ensure that impounded overloaded vehicles, violations of Exemption Permits, Bypassing/absconding vehicles are prohibited and prosecuted as per the applicable axle load laws and compliance is achieved after payment of relevant fees/fines before vehicles are released.
- Coordinate with the police on prosecution of impounded vehicles/trucks.
- Operate computerized prosecution system.
- Advise transporters on load correction and overload fee payment.
- Keep track/records of all prohibited/prosecuted trucks/vehicles both for static and mobile.
- Attend to court proceedings when required.
- Ensure prohibited vehicles are clamped to prevent them from escaping.
- Raise compliance certificate to trucks which have complied.
- Reconciling the fines paid in court with recommended fines.
- Perform any other duties as will be assigned from time to time.

#### **Site Staff 9: General Assistant**

- The Staff proposed as a General Assistant must possess a minimum average grade of C-(Minus) in Kenya Certificate of Secondary Education (KCSE) or equivalent grade for other education systems.
- He/she shall have a minimum of three (3) years hands-on experience as a clerk (or equivalent) in a technical facility/project.
- Proficiency in computer applications.

[October 2024]

- Fulfilled the requirements of Chapter Six of the Constitution.

#### **Detailed Tasks Assigned**

- Guide vehicles to the scale.
- Ensure proper axle positioning before the assigning of the weight.
- Verify and assist Computer Operator Weighing to capture accurate vehicle information of trucks i.e. vehicle registration numbers, transporter details, axle configurations, presence of dummy and lift axles etc. as per weighbridge procedures.
- Communicate immediately with Traffic Police Officers in cases where violation to instruction happens.
- Ensure that all trucks that are found to be overloaded with either gross/axle overloads are directed to the yard and properly documented.
- Assist the Vehicle Inspectors to take measurements for wide loads.
- Should be able to relieve the Computer Operator Weighing.
- Perform any other duties as will be assigned from time to time.

#### **Site Staff 10: General Workers/Support Staff**

- The Staff proposed as a General Workers/Support Staff must possess a minimum average grade of D+ (Plus) in Kenya Certificate of Secondary Education (KCSE) or equivalent grade for other education systems.
  - Fulfilled the requirements of Chapter Six of the Constitution.

#### **Detailed Tasks Assigned**

- Responsible for cleaning the workspaces, including restrooms; emptying trash bins, cleaning windows, and dusting furniture, and performing other related duties to promote a tidy environment for all.
- Ensure high level of cleanliness with the weighbridge facility and other job as assigned by the Manager.
- Ensure that buildings are always cleaned. These include floors, windows, toilet facilities, kitchen and offices.
- Gardening and ensuring the compound is without litter and grass is slashed to required standards.
- Follow safety and quality procedures in executing all tasks assigned.
- Ensure that the drainages within the station are well maintained.
- Any other work/responsibilities as may be assigned by the office.

#### **Site Staff 10: Security Guards**

- **The Private Security guards (from a reputable Security Firm)** shall be approved by the Engineer before they can be deployed into the weighbridges.
- The Staff proposed as a Security Guard must possess a minimum average grade of D (Plain) in Kenya Certificate of Secondary Education (KCSE) or equivalent grade for other education systems.
- Personnel deployed as Security Guards must fulfill the requirements of Chapter Six of the Constitution.

#### **Detailed Tasks Assigned**

- In close liaison with the police, offer additional security services to ensure trucks held at the weighbridge are safe and Secure.

[October 2024]

- Man all key installations including High Speed Weigh in Motion Equipment gantries, Street lights, and gates.
- Clamping of trucks at the holding yard.
- Control of Entrance/Exit movements to ensure only Authorized Personnel Access the Weighbridges
- Observation and Surveillance to Identify persons at the weighbridge without Authorization and handing them over to the police officers for prosecution.
- Provide a Visible Security Presence to Deter Potential Crimes & Unruly behaviors.
- Conducting Regular Patrols & Inspections of Weighbridge facilities.
- Writing Accurate & Detailed Incident Reports including registering visitors.

**TEMPORARY SITE STAFF: FOREMAN (CIVIL WORKS)**

- The Staff proposed as Foreman must possess a Diploma in Civil Engineering from a recognized institution.
- The person must be registered with KETRB/IET.
- He/she must have a minimum Experience of 5yrs in construction works.
- The person shall be engaged temporarily during construction of the concrete slabs.

*To enhance integrity among the Weighbridge Staff, the Management Contractor shall ensure that at all times, the monthly salaries of his staff are paid on or before the last day of the month. Failure to do so shall amount to a breach of contract and the Engineer shall advise the Employer to commence Contract termination process if this occurs for the third time in the contract other than the penalty of surcharge at the rate of Kenya Shillings 100,000 (One hundred thousand) per day for all the days that the payments have been delayed.*

## 5.11 WORK SCHEDULE

The contractor shall propose a schedule of activities and corresponding deployment of manpower, which will ensure that all duties entrusted to him, will be performed. This schedule, together with a comprehensive statement justifying the proposed deployment will be incorporated in the methodology statement.

## 5.12 PROVISION OF TRANSPORT

### 5.12.1 Network Monitoring

The Contractor shall provide including fuel, driver and maintenance of 1 No. brand new **4 Wheel Drive Double cab pickup of 2800cc - 3000cc engine capacity for use as his/her Network Monitoring Equipment by the mobile weighbridge teams**. In addition, the Contractor shall also provide including fuel, driver and maintenance of a brand new **4 Wheel Drive Double cab pickup of 2800cc - 3000cc engine capacity for the Cluster Manager to enable him/her monitor and coordinate operations effectively within the weighbridge Cluster under his/her supervision**. The vehicles must be fitted with bull bars and communication equipment for ease of monitoring of the operations of the mobile units. The Contractor shall include in his rates amounts required for the provision and operation of these unit vehicles specially fitted for Monitoring of the Contract Network. The contractor shall obtain the Engineer's approval, to ensure they meet the assignment needs, on the applicability of the vehicle before deployment and commencement of the assignment. The vehicles will revert to the Contractor.

### 5.12.2 Mobile Monitoring

Other than the daily 24-hour mobile monitoring, the contractor shall carry out an intensive ten (10) day intensive enforcement operation every quarter to clear any pockets of non – compliant networks within their cluster. A daily mobile network monitoring for each team shall not weigh

[October 2024]

less than 50 vehicles and cover a network of not less than 150 kilometres *Where a quarterly 10 day intensive enforcement operation has not been conducted in the due quarter, a recovery in the quantum of KShs 1,000,000 (One Million Kenya Shillings) shall be made from the Interim Payment Certificate (IPC) of the subsequent quarter to ensure compliance with this provision. This will be instrumental in dealing with resistance in some parts of cluster(s) which may develop such tendencies. This penalty shall be doubled where there is failure for the second and subsequent quarters and shall not be recoverable by the Contractor whatsoever for the forgone service.*

### 5.12.3 Engineers' Supervision Vehicles

The Contractor shall **provide, fuel and maintain 2 No. Brand New 4 Wheel Drive Double cab pickup Vehicles of 2800cc - 3000cc engine capacity including driver, fuel and service for the exclusive use of the Engineer inclusive of the first 4,000km per vehicle month in accordance with clause 138 of Standard Specifications.**

**The contractor shall charge for his Overheads and profits for provision of those vehicles beyond the monthly mileage of 4,000kms per km of extra mileage covered for that particular month.**

*All these vehicles shall be provided with fuel cards to facilitate superintendence for the duration of the contract.*

The vehicle shall revert to the contractor at the end of contract.

## 5.13 FACILITIES TO BE PROVIDED BY THE CONTRACTOR

Besides personnel inputs, the contractor shall provide equipment, and all other inputs required to render the services. The contractor shall pay for provision and maintenance of all services and utilities. Where the contractor requires additional space for office accommodation, such as for housing the control area, the contractor may provide a prefabricated or containerised office for that purpose at his/her cost.

## 5.14 FACILITIES TO BE PROVIDED BY THE EMPLOYER

Under the Terms and Conditions of the Management Contract, the Contractor shall be provided with: -

- A building housing the contractor's site office and associated installations for operations on site.
- Where the contractor is instructed to provide hardware and software, the same shall be paid for in the applicable item in the bills of quantities.
- Equipment, furnishing and any other infrastructure on site

It shall be the responsibility of the Contractor to supervise the supply and provision and maintenance of the said buildings, furniture and equipment by the Employer in accordance with the Management contract. **The Contractor shall ensure that any items designated to revert to the Employer after completion of the Contract are officially handed over in good condition or as they were at the start of the contract.**

[October 2024]

## 5.15 REPORTS

The Contractor shall prepare **Monthly Management Reports** during the period of execution of the works contract and **submit them within 7 days after the end of the reporting month. Quarterly Summary Reports** shall be prepared every successive period of 3 months and **submitted within 7 days after the end of the reporting period.** An annual summary report will be prepared at the end of every calendar year and submitted 10 days after the lapse of the year. **The Final Project Completion Report shall be submitted within 30 days after the expiry of the contract.**

**To: Director General  
Kenya National Highways Authority  
P. O. Box 49712-00100  
NAIROBI**

The reports shall be written in English and shall be submitted in the number of copies tabulated below.

The **Final Project Completion Report** shall comprehensively evaluate the project with regard to the Management contract, include a summary of the principle difficulties encountered during management and the means employed to overcome them, changes made in the original operations manual and schedule. The report may make any overall observations or recommendations that the Contractor wishes to draw to the attention of the Engineer and the Employer as regards the management contract.

**In the Methodology Statement, the Contractor shall provide a fixed layout for these reports,** which shall conform to the layout in the attached **Attachment B** whichever is applicable. The reports shall be submitted as follows: -

### (a) Daily and weekly Reports

These will be submitted electronically to the Engineer's Representative both in form of short message service (SMS) and email.

### (b) Report to be submitted when taking over the facility phase

Ten copies to be provided

### (c) Report to be submitted during Operations Management Period and at completion including a soft copy.

<b>Report</b>	<b>No. of copies</b>
<i>Inception Report</i>	3
<i>Monthly Management reports</i>	3
<i>Quarterly Progress Summary Reports</i>	3
<i>Annual Reports</i>	3
<i>Final Project Completion Report</i>	3

### (d) Documentation and Reports on Facilities provided by the Contractor

Comprehensive Documentation and Reports on Facilities provided by the Contractor shall be provided, including the following:

- Current equipment System architecture diagrams.
- Description of each module.
- Overview description of software.
- Passwords and Security Keys



[October 2024]

Equipment manuals.  
Set up and test procedures.  
Records of tests conducted.  
Fault finding procedures.  
As installed' drawings for equipment provided and installed by the contractor  
Electrical/Software Maintenance manuals.  
Operator's manuals.

## **5.16 MONITORING AND EVALUATION**

### **5.16.1 Definition of indicators**

In his Technical Proposal (Organisation and Methodology), the Contractor shall propose relevant Key Performance Indicators for monitoring project progress, results, activities and assumptions and show how these will be monitored.

Key indicators shall include;

- The percentage of vehicles weighed vs. the vehicles passing at the diversion and
- Installation of systems to ensure that weighing is carried out correctly, data captured and stored in a computerised system and transporters issued with a printed ticket at the static scales.

The integrated weighbridge management system to be used for the weighbridge operations will be provided by the client. The contractor will pay for the licence and upgrade fees and be reimbursed as per the bill of quantity. The system is programmed to take instant front vehicle photos for suspected overloaded vehicles and the information backed up in the servers. The System is also integrated with the Virtual and Mobile Weighbridges for seamless data sharing on Axle Loads.

The Contractor will regularly appraise this information in his Management reports and in Site Meetings and discuss them with the Employer and the Engineer.

### **5.16.2 Reviews and Evaluations**

Project reviews and evaluation applying monitoring indicators will be presented in the regular management reports and the Final Project Completion Report will contain an overall assessment.

[October 2024]

## ATTACHMENT A

### REQUIRED INFORMATION TO BE INCLUDED IN MONTHLY PROGRESS REPORT

#### 1. AXLE LOAD CONTROL AT WEBUYE WEIGHBRIDGE STATION AND THE 2073 KM ADJACENT ROAD NETWORK.

Table 1: Monthly Statistics

Contents: Number of vehicles per category of axle configuration of vehicle (i.e., 3A, 4A, 5A, 6A, 6B, 6C, 7A etc)  
Diverted  
Weighed  
Overloaded  
Percentage overloaded  
Average overload (kg)  
Number charged  
Percentage charged  
Total of all weighed and aggregated statistics  
Total Number of vehicles passing the diversion (whether weighed or not)  
Computed aggregated standard axles passing  
Computed pavement damage factors

Table 2: Daily and Hourly Statistics

Contents: Number of vehicles weighed per hour per day  
Number of vehicles passing the diversion per hour per day

Table 3: Top offenders by company with more than 10 vehicles overloaded per month or more than 5 charged per month detailing;

Contents: Name of company  
Number of vehicles weighed  
Number of vehicles overloaded  
Percentage overloaded  
Number charged  
Percentage charged

Table 4: Top offenders by both axle and gross vehicle weight overload per month detailing;  
Name of company  
Date impounded  
Origin and destination of journey  
Quantity of overload

#### Type of Cargo

Figure 1: Monthly Statistics

Contents: Graph showing the following information per month for the last 12 months:  
Vehicles weighed  
Vehicles overloaded  
Vehicles charged

Figure 2: Daily Statistics

Contents: Graph showing the following information per day for the report month:

[October 2024]

Vehicles weighed  
Vehicles overloaded  
Vehicles charged

There should be a narrative on the following;

Activities in the month say repairs/ visitors/incidents  
Fines due and collected  
Staff matters; changes, discipline cases etc)  
Changes executed in operations.

**Figure 3: Percentage overload**

Contents: Graph showing percentage vehicles overloaded per month for the last 12 months (one graph per direction on the Road)

Figure 4: Average monthly percentage overload: type of axle

Contents: Graph showing average percentage overload per month for the last 12 months for:

Single axles  
Tandem axle units  
Tridem axle units

Figure 5: Average monthly percentage overload: number of axles

Contents: Graph showing average percentage overload per month for the last 12 months for:

2 axle vehicles  
3 axle vehicles  
4 axle vehicles  
5 axle vehicles  
6 axle vehicles  
7 Axle vehicles  
Vehicles with more than 7 axles

Figure 6: Monthly average of 20, 50 and 100 maximum overloads

Contents: Graph showing the average overload in kg for the 20<sup>th</sup>, 50<sup>th</sup>, and 100 percentile overloads

[October 2024]

## ATTACHMENT B

### SERVICE PROVIDERS AT WEIGHBRIDGE SITES: POLICY AND CODE OF CONDUCT.

#### 1. BACKGROUND

The services of a third party are often needed by hauliers at weighbridges for the following activities:

- Moving of loads from one vehicle to another
- Redistribution of loads
- Repairs to vehicles
- Rectifying vehicles that are not roadworthy.
- Legal assistance

#### 2. POLICY ON ACTIVITIES OF SERVICE PROVIDERS

Service providers shall obtain permission in writing from the Engineer.

Service providers must accept, in writing, a Code of Conduct before permission is granted to operate on site. Permission will be withdrawn if the operator acts in contravention of the Code of Conduct.

Activities of service providers must be related to the overload control process.

No sales or trading business will be allowed at the weighbridge station.

Service providers shall not store their equipment on site.

Service providers shall not wait on site for potential clients. They are allowed to display the nature of the service rendered, as well as their contact details, on public notice boards at the weighbridge station. No other form of advertising such as billboards, distribution of leaflets, etc. will be permitted on site.

The management contractor will not give information about any person, vehicle or transgression relating to the law enforcement at the site to service providers.

Service providers shall deliver proof of third-party insurance for any damage to property or injury to a person on site for which the provider is liable, before permission is granted to operate.

Service providers shall indemnify the Authority for damage, theft or injury caused to persons or property, by their presence or actions on site.

If a service provider is caught loading overloaded pay-load back on to a previously overloaded vehicle after such vehicle has been released from the weighbridge station, his licence to operate at the station will be withdrawn immediately.

#### 3. CODE OF CONDUCT FOR SERVICE PROVIDERS

In recognition that weighbridge sites have restricted access, a service provider shall conduct himself/herself according to the following:

He/ She shall visit the weighbridge only on request of a haulier, and in order to perform a specific task.

The service provider must report to the Weighbridge Manager or the Police Officer on arriving at site and before commencing the task.

He/she shall not interfere with the day-to-day functioning of the centre's operation and the flow of traffic.

Access to the security area at the control room will not be permitted.

The service provider is expected to conduct his/her business in a socially acceptable manner.

Strong language or aggressive attitudes will not be permitted.

Use of alcohol will not be permitted on site.

Once a service has been rendered the provider shall leave the site immediately.

Actions on site shall be subject to the Laws of Kenya in relation to occupational health and safety and care for environment.

[October 2024]

## **SECTION 6: GENERAL CONDITIONS OF CONTRACT (FIDIC CONDITIONS)**

### **1. GENERAL PROVISIONS**

- 1.1 Definitions** Unless the context otherwise requires, the following terms whenever used in this Contract shall have the following meanings:
- (a) “Applicable Law” means the laws and any other instruments having the force of law in the Republic of Kenya as they may be issued and in force from time to time;
  - (b) “Contract” means the Contract signed by the Parties, to which these General Conditions of Contract (GC) are attached together with all the documents listed in Clause 1 of such signed Contract;
  - (c) “Contract Price” means the price to be paid for the performance of the Services in accordance with Clause 6 here below;
  - (d) “Foreign Currency” means any currency other than the Kenya Shilling;
  - (e) “GC” means these General Conditions of Contract;
  - (f) “Government” means the Government of the Republic of Kenya;
  - (g) “Local Currency” means the Kenya Shilling;
  - (h) “Member”, in case the Contractor consists of a joint venture of more than one entity, means any of these entities; “Members” means all these entities, and “Member in Charge” means the entity specified in the SC to act on their behalf in exercising all the Contractor’s rights and obligations towards the Client under this Contract;
  - (i) “Party” means the Client or the Contractor, as the case may be, and “Parties” means both of them;
  - (j) “Personnel” means persons hired by the Contractor or by any Subcontractor as employees and assigned to the performance of the Services or any part thereof;
  - (k) “SC” means the Special Conditions of Contract by which the GC may be amended or supplemented;
  - (l) “Services” means the work to be performed by the Contractor pursuant to this Contract; and
  - (m) “Subcontractor” means any entity to which the Contractor subcontracts any part of the Services and Works in accordance with the provisions of Clauses 3 and 4.
- 1.2 Law Governing** This Contract, its meaning and interpretation and the the Laws of Kenya shall govern the Contract relationship between the Parties.
- 1.3 Language** This Contract has been executed in English language which shall be the binding and controlling language for all matters relating to the meaning or interpretation of this Contract.
- 1.4 Notices** Any notice, request, or consent made pursuant to this Contract shall be in writing and shall be deemed to have been made when delivered in person to an

[October 2024]

authorized representative of the Party to whom the communication is addressed or when sent by registered mail, telex, telegram or facsimile to such Party at the address specified in the SC.

- 1.5 Location** the Services shall be performed at such locations as are specified and, where the location of a particular task is not so specified, at such locations, whether in the Republic of Kenya or elsewhere, as the Client may approve.
- 1.6 Authorized Representative's** Any action required or permitted to be taken and any document required or permitted to be executed under this Contract by the Client or the Contractor may be taken or executed by the officials specified in the SC.
- 1.7 Taxes and Duties** The Contractor, Subcontractor [s] and their personnel shall pay such taxes, duties, fees and other impositions as may be levied under the Laws of Kenya, the amount of which is deemed to have been included in the Contract Price.

## **2. COMMENCEMENT, COMPLETION, MODIFICATION AND TERMINATION OF CONTRACT**

- 2.1 Effectiveness of Contract** This Contract shall come into effect within 14 days after signature or such other later date as may be stated in the SC.
- 2.2 Commencement of Services** the Contractor shall begin carrying out the Services twenty eight (28) days after the date the Contract becomes effective or at such other date as may be specified in the SC.
- 2.3 Expiration of Contract** Unless terminated earlier pursuant to Clause 2.6, this Contract shall terminate at the end of specified in the SC.
- 2.4 Modification** Modification of the terms and Conditions of this Contract, including any modification of the scope of the Services or the Contract Price, may only be made by written agreement between the Parties.
- 2.5 Force Majeure**
- 2.5.1 Definition** For the purposes of this Contract, "Force Majeure" means an event which is beyond the reasonable control of a Party and which makes a Party's performance of its obligations under the Contract impossible or so impractical as to be considered impossible under the circumstances.
- 2.5.2 No Breach of Contract** The failure of a Party to fulfil any of its obligations under the Contract shall not be considered to be a breach of, or default under, this Contract insofar as such inability arises from an event of Force Majeure, provided that the Party affected by such an event (a) has taken all reasonable precautions, due care and reasonable alternative measures in order to carry out the terms and conditions of this Contract, and (b) has informed the other Party as soon as possible about the occurrence of such an event.
- 2.5.3 Extension Of Time** Any period within which a Party shall, pursuant to this Contract complete any action or task shall be extended for a period equal to the time during which such Party was unable to perform such action as a result of Force Majeure.

[October 2024]

**2.5.4 Payments** During the period of his inability to perform the Services as a result of an event of Force Majeure, the Contractor shall be entitled to continue to be paid under the terms of this Contract, as well as to be reimbursed for additional costs reasonably and necessarily incurred by him during such period for the purposes of the Services and in reactivating the Service after the end of such period.

## **2.6 Termination**

### **2.6.1 By the Client**

The Client may terminate this Contract by not less than twenty-eight (28) days' written notice of termination to the Contractor, to be given after the occurrence of any of the events specified in this Clause;

- (a) If the Contractor does not remedy a failure in the performance of his obligations under the Contract within twenty-eight (28) days after being notified or within any further period as the Client may have subsequently approved in writing;
- (b) If the Contractor becomes insolvent or bankrupt;
- (c) If, as a result of Force Majeure, the Contractor is unable to perform a material portion of the Services for a period of not less than sixty (60) days; or
- (d) If the Contractor, in the judgement of the Client, has engaged in corrupt or fraudulent practices in competing for or in executing the Contract.

For the purpose of this clause;

“Corrupt practice” means the offering, giving, receiving or soliciting of anything of value to influence the action of a public official in the selection process or in Contract execution.

“Fraudulent practice” means a misrepresentation of facts in order to influence a selection process or the execution of Contract to the detriment of the Client and includes collusive practice among Bidders (prior to or after submission of proposals) designed to establish prices at artificial non-competitive levels and to deprive the Client of the benefits of free and open competition.

- (e) If the Client in his sole discretion decides to terminate this Contract.
- (f) If the Contractor is unable to service his financial obligations under the contract including payments of salaries to his own employees and other officers that the Employer has seconded to the weighbridge for purposes of the execution of the contract for a period of at least two consecutive months. Then the Employer would deem this to be a breach of contract by the contractor and shall constitute a ground for termination of Contract.

### **2.6.2 By the Contractor**

The Contractor may terminate this Contract by not less than thirty (30) days' written notice to the Client, such notice to be given after the occurrence of any of the following events;

[October 2024]

- (a) If the Client fails to pay any monies due to the Contractor pursuant to this Contract and not subject to dispute pursuant to Clause 7 within sixty (60) days after receiving written notice from the Contractor that such payment is overdue; or
- (b) If, as a result of Force Majeure, the Contractor is unable to perform a material portion of the Services for a period of not less than sixty (60) days.

**2.6.3 Payment Upon Termination**

Upon termination of this Contract pursuant to Clauses 2.6.1 or 2.6.2, the Client shall make the following payments to the Contractor:

- (a) remuneration pursuant to Clause 6 for Services satisfactorily performed prior to the effective date of termination;
- (b) Except in the case of termination pursuant to paragraphs (a) and (b) of Clause 2.6.1, reimbursement of any reasonable cost's incident to the prompt and orderly termination of the Contract, including the cost of the return travel of the Personnel and their eligible dependents.

**3. OBLIGATIONS OF THE CONTRACTOR**

**3.1 General**

The Contractor shall perform the Services and carry out his obligations with all due diligence, efficiency and economy in accordance with accepted professional techniques and practices and shall observe sound management practices and employ appropriate advanced technology and safe methods. The Contractor shall always act, in respect of any matter relating to this Contract or to the Services, as a faithful adviser to the Client and shall at all times support and safeguard the Client's legitimate interests in any dealing with Sub bidders or third parties.

**3.1.1 Payments to facilitate effective Contract Supervision by the Engineer's Representative**

The Contractor shall ensure timely release of payments to facilitate the delivery of services. These shall be instructed by the Engineer's Representative to facilitate those officers attending court, salaries and allowances payable to the Engineer's staff. The Contractor shall put in place mechanisms to facilitate efficient release of such funds to the officers not later than three working days after the receipt of such instructions. Any delays arising thereof shall result in non - payments of the Contractor's extra over item for overheads and profits at the rate quoted by the Contractor for the item in the subsequent month. This is intended to enhance integrity among staff as they carry out their duties and to avoid non-attendance to matters coming up in court.

**3.2 Conflict of Interests**

**3.2.1 Contractor Not to Benefit from Commissions, Discounts Etc.**

- (i) The remuneration of the Contractor pursuant to Clause 6 shall constitute the Contractor's sole remuneration in connection with this Contract or the Services and the Contractor shall not accept for his own benefit any trade commission, discount or similar payment in connection with



[October 2024]

activities pursuant to this Contract or to the Services or in the discharge of his obligations under the Contract and the Contractor shall use his best efforts to ensure that his personnel, any subcontractor[s] and agents of either of them similarly shall not receive any such additional remuneration.

- (ii) For a period of two years after the expiration of this Contract, the Contractor shall not engage and shall cause his personnel as well as his subcontractor [s] and his/their personnel not to engage in the activity of a purchaser (directly or indirectly) of the assets on which he advised the Client on this Contract nor shall he engage in the activity of an adviser (directly or indirectly) of potential purchasers of such assets.
- (iii) Where the Contractor as part of the Services has the responsibility of advising the Client on the procurement of goods, works or services, the Contractor will comply with any applicable procurement guidelines and shall at all times exercise such responsibility in the best interest of the Client. Any discounts or commissions obtained by the Contractor in the exercise of such procurement shall be for the account of the Client.

**3.2.2 Contractor and Affiliates Not to be Otherwise Interested in Project**

The Contractor agrees that, during the Contract and after its termination, the Contractor and his affiliates, as well as any Subcontractor and any of his affiliates, shall be disqualified from providing goods, works or services (other than the Services and any continuation thereof) for any project resulting from or closely related to the Services.

**3.2.3 Prohibition of Conflicting Activities**

Neither the Contractor nor his subcontractor[s] nor their personnel shall engage, either directly or indirectly in any of the following activities:

- (a) During the term of this Contract, any business or professional activities in the Republic of Kenya which would conflict with the activities assigned to them under this Contract; or
- (b) After the termination of this Contract, such other activities as may be specified in the SC.

**3.3 Confidentiality**

The Contractor, his subcontractor[s] and the personnel of either of them shall not, either during the term of this Contract or within two (2) years after the expiration of this Contract, disclose any proprietary or confidential information relating to the Project, the Services, this Contract or the Client's business or operations without the prior written consent of the Client.

**3.4 Insurance to be Taken Out by the Contractor**

The Contractor (a) shall take out and maintain and shall cause any subcontractor[s] to take out and maintain, at his (or the subcontractors, as the case may be) own cost but on terms and conditions approved by the Client, insurance against the risks and for the coverage, as shall be

[October 2024]

specified in the SC; and (b) at the Client's request, shall provide evidence to the Client showing that such insurance has been taken out and maintained and that the current premiums have been paid.

**3.5 Contractor's Actions requiring Client's Prior Approval**

The Contractor shall obtain the Client's prior approval in writing before taking any of the following actions;

- a) Entering into a subcontract for the performance of any part of the Services,
- b) Appointing such members of the personnel not listed by name in Appendix A ("Key Personnel and Sub Contractors").

**3.6 Reporting Obligations**

The Contractor shall submit to the Client the reports and documents specified in Attachment A in the form, in the numbers, and within the periods set forth in the said Attachment.

**3.7 Documents Prepared by the Contractor to Be the Property Of the Client**

All plans, drawings, specifications, designs, reports and other documents and software submitted by the Contractor in accordance with Clause 3.6 shall become and remain the property of the Client and Contractor shall, not later than upon termination or expiration of this Contract, deliver all such documents and software to the Client together with a detailed inventory thereof. The Contractor may retain a copy of such documents and software. Neither Party shall use these documents for purposes unrelated to this Contract without the prior approval of the other Party.

**4. CONTRACTOR'S PERSONNEL**

**4.1 Description Of Personnel**

The titles, agreed job descriptions, minimum qualifications and estimated periods of engagement in the carrying out of the Services of the Contractor's Key Personnel are described in Appendix A

**4.2 Removal Replacement Of Personnel**

(a) Except as the Client may otherwise and/or agree, no changes shall be made in the key personnel. If for any reason beyond the reasonable control of the Contractor, it becomes necessary to replace any of the Key Personnel, the Contractor shall provide as a replacement a person of equivalent or better qualifications. The Operations Manager, the Technical Manager and the Systems Administrators Services and the Weighbridge Cluster Manager shall NOT be terminated without the prior concurrence of the Engineer.

(b) If the Client finds that any of the Personnel have (i) committed serious misconduct or have been charged with having committed a criminal action, or (ii) the Client has reasonable cause to be dissatisfied with the performance of any of the Personnel, then the Contractor shall, at the Client's written request specifying the grounds thereof, provide as a

[October 2024]

replacement a person with qualifications and experience acceptable to the Client.

(c) The Contractor shall have no claim for additional costs arising out of or incidental to any removal and/or replacement of Personnel.

## 5. OBLIGATIONS OF THE CLIENT

### 5.1 Assistance and Exemptions

The Client shall use his best efforts to ensure that he provides the Contractor such assistance and exemptions as may be necessary for due performance of this Contract.

### 5.2 Change in the Applicable Law

If after the date of this Contract, there is any change in the Laws of Kenya with respect to taxes and duties which increases or decreases the cost of the Services rendered by the Contractor, then the remuneration and reimbursable expenses otherwise payable to the Contractor under this Contract shall be increased or decreased accordingly by agreement between the Parties and corresponding adjustments shall be made to the amounts referred to in Clause 6.2 (a) or (b), as the case may be.

### 5.3 Services and Facilities

The Client shall make available to the Contractor the Services and Facilities listed in the Data Sheet Clause 1.4 and under Terms of Reference Clause 6.4.

## 6. PAYMENTS TO THE CONTRACTOR

### 6.1 Monthly Remuneration

The Contractor's total remuneration shall not exceed the Contract Price and shall be based on monthly payments. Except as provided in Clause 5.2, the Contract Price may only be increased above the amounts stated in Clause 6.2 if the Parties have agreed to additional payments in accordance with Clause 2.4.

### 6.2 Contract Price

The price payable is set forth in the Special Conditions.

### 6.3 Payment for Additional Services

For the purposes of determining the remuneration due for additional services as may be agreed under Clause 2.4, a breakdown of the Contract price is provided in Annex B.

### 6.4 Terms and Conditions of Payment

Payments will be made to the account of the Contractor and according to the payment schedule stated in the "Special Conditions of Contract".

### 6.5 Interest on Delayed Payment

Payment shall be made within Ninety (90) days of receipt of Interim Monthly Certificate and the relevant document specified in Clause 6.4. If the Client has delayed payments beyond ninety (90) days after the due date hereof, simple interest shall be paid to the Contractor for each day of delay at a rate three percentage points above the prevailing Central Bank of Kenya's average rate for base lending.

[October 2024]

## **7. SETTLEMENT OF DISPUTES**

### **7.1 Amicable Settlement**

The Parties shall use their best efforts to settle amicably all disputes arising out of or in connection with this Contract or its interpretation.

### **7.2 Dispute Settlement**

Any dispute between the Parties as to matters arising pursuant to this Contract that cannot be settled amicably within thirty (30) days after receipt by one Party of the other Party's request for such amicable settlement may be referred by either Party to the arbitration and final decision of a person to be agreed between the Parties. Failing agreement to concur in the appointment of an Arbitrator, the Arbitrator shall be appointed by the Chairman of the Chartered Institute of Arbitrators, Kenya Branch, on the request of the applying party.

[October 2024]

## SECTION 7: SPECIAL CONDITIONS OF CONTRACT

Number of GC Clause	Amendments of and Supplements to Clauses in the General Conditions of Contract
1.1 1.2	The Member in Charge is <b>Eng. Kungu Ndungu</b> The addresses are:  Client: Director General, Kenya National Highways Authority Attention: Eng. Kungu Ndungu Telephone: 020 – 8013842 Email: <a href="mailto:dg@kenha.co.ke">dg@kenha.co.ke</a> / <a href="mailto:info@kenha.co.ke">info@kenha.co.ke</a> Website: <a href="http://www.kenha.co.ke">www.kenha.co.ke</a>
1.3	The Authorized Representatives are:  For the Client: Director, Maintenance  For the Contractor
2.1	The date on which this Contract shall come into effect is immediately after contract is signed by both parties.
2.2	The date for the commencement of Services is within 14 days after contract signature.
2.3	The period shall be 28 Months.
2.4	<b>The Contractor in the performance of his obligations is required to respond to Client’s queries on operations within seven (7) days after being notified of the same.</b>
3.0	The risks and coverage shall be:  (i) Professional Liability: <b>Full amount of this contract excluding taxes and contingency amount.</b>  (ii) Loss of or damage to equipment and property: <b>KSh 50,000,000</b>  (iii) Third party Liability: <b>KSh 50,000,000</b>  (iv) Employer’s Liability and workers compensation: <b>KSh 10,000,000</b>
4.0	Payments shall be made on monthly basis.  Payments in KSh shall be made to the following Account Account Number: _____ Account Name: _____ Bank: _____

[October 2024]

Address: \_\_\_\_\_

- 5.0 Payments will be made within 90 (ninety) days of receipt of the Interim Monthly Certificate and the relevant documents specified in Clause 6.4 above.

**STANDARD SPECIFICATIONS FOR ROAD AND BRIDGE CONSTRUCTION 1986 EDITION**

Standard Specifications refers to the Standard Specifications for Road and Bridge Construction, 1986 Edition. This would be used where improvement works are to be undertaken.

**CONDITIONS OF CONTRACT PART I: GENERAL CONDITIONS OF CONTRACT**

The Conditions of Contract Part 1 – General Conditions shall be those forming Part 1 of the Conditions of Contract for works of Civil Engineering Construction Fourth Edition 1987, reprinted in 1992 with further amendments, prepared by the Federation Internationale des Ingenieurs Conseils (FIDIC)

Copies of the FIDIC Conditions of Contract can be obtained from:

FIDIC Secretariat  
P.O. Box 86  
1000 Lausanne 12

**Switzerland**

Fax: 41 21 653 5432  
Telephone: 41 21 653 5003

[October 2024]

## **SECTION XI - CONTRACT FORMS**

### **TABLE OF FORMS**

FORM No. 1 - NOTIFICATION OF INTENTION TO AWARD

FORM No. 2 - REQUEST FOR REVIEW

FORM No. 3 - NOTIFICATION OF AWARD - LETTER OF ACCEPTANCE

FORM No. 4 - CONTRACT AGREEMENT

FORM No. 5 - PERFORMANCE SECURITY [Option 1 - Unconditional Demand Bank Guarantee]

FORM No. 6 - ADVANCE PAYMENT SECURITY

FORM No. 7 - RETENTION MONEY SECURITY

FORM No. 8 - BENEFICIAL OWNERSHIP DISCLOSURE FORM

[October 2024]

**FORM NO. I - NOTIFICATION OF INTENTION TO AWARD**

**[This Notification of Intention to Award shall be sent to each Tenderer that submitted a Tender.] [Send this Notification to the Tenderer's Authorized Representative named in the Tender Information Form]**

**FORMAT**

For the attention of Tenderer's Authorized Representative

Name: ..... [insert Authorized Representative's name] Address: [insert Authorized Representative's Address] Telephones: [insert Authorized Representative's telephone/fax numbers] Email Address: [insert Authorized Representative's email address]

**[IMPORTANT: insert the date that this Notification is transmitted to Tenderers. The Notification must be sent to all Tenderers simultaneously. This means on the same date and as close to the same time as possible.]**

**Date of Transmission:**

This Notification is sent by: [email] on [date] (local time)

Procuring Entity: [insert the name of the Procuring entity]

Contract title: [insert the name of the contract]

Country: Kenya, County \_\_\_\_\_ (if the Procuring Entity is from a County)

This Notification of Intention to Award (Notification) notifies you of our decision to award the above contract. The transmission of this Notification begins the Standstill Period. During the Standstill Period, you may:

- a) Request a debriefing in relation the evaluation of your Tender, and/or
- b) Submit a Procurement-related Complaint in relation to the decision to award the contract.

**1. The successful Tenderer**

Name: [insert name of successful Tenderer] Address: [insert address of the successful Tenderer] Contract price: [insert contract price of the successful Tender]

**2. Other Tenderers: insert names of all Tenderers that submitted a Tender. If the Tender's price was evaluated include the evaluated price as well as the Tender price as read out.]**

	Name of Tenderer	Tender price	Evaluated Tender price	Comments (if any)
1				
2				
3				
6				
7				
Etc.				



[October 2024]

## 1. How to request a debriefing

**DEADLINE:** The deadline to request a debriefing expires at midnight on [*insert date*] (local time).

You may request a debriefing in relation to the results of the evaluation of your Tender. If you decide to request a debriefing your written request must be made within three (3) Business Days of receipt of this Notification of Intention to Award. Provide the contract name, reference number, name of the Tenderer, contact details; and address the request for debriefing as follows:

**Attention:** [*insert full name of person, if applicable*] **Title/position:** [*insert title/position*]

**Procuring Entity:** [*insert name of Procuring Entity*] **Email address:** [*insert email address*]

If your request for a debriefing is received within the 3 Business Days deadline, we will provide the debriefing within five (5) Business Days of receipt of your request. If we are unable to provide the debriefing within this period, the Standstill Period shall be extended by five (5) Business Days after the date that the debriefing is provided. If this happens, we will notify you and confirm the date that the extended Standstill Period will end. The debriefing may be in writing, by phone, video conference call or in person. We shall promptly advise you in writing how the debriefing will take place and confirm the date and time.

If the deadline to request a debriefing has expired, you may still request a debriefing. In this case, we will provide the debriefing as soon as practicable, and normally no later than fifteen (15) Business Days from the date of publication of the Contract Award Notice.

## 2. How to make a complaint

**Period:** Procurement-related Complaint challenging the decision to award shall be submitted by midnight, [*insert date*] (local time).

Provide the contract name, reference number, name of the Tenderer, contact details; and address the Procurement- related Complaint as follows:

**Attention:** [*insert full name of person, if applicable*]

**Title/position:** [*insert title/position*]

**Procuring Entity:** [*insert name of Procuring Entity*]

**Email address:** [*insert email address*]

At this point in the procurement process, you may submit a Procurement-related Complaint challenging the decision to award the contract. You do not need to have requested, or received, a debriefing before making this complaint. Your complaint must be submitted within the Standstill Period and received by us before the Standstill Period ends.

In summary, there are four essential requirements:

- a) You must be an 'interested party'. In this case, that means a Tenderer who submitted a Tender in this tendering process, and is the recipient of a Notification of Intention to Award.
- b) The complaint can only challenge the decision to award the contract.
- c) You must submit the complaint within the period stated above.

[October 2024]

- d) You must include, in your complaint, all of the information necessary to support your case.
- e) The application must be accompanied by the fees set out in the Procurement Regulations, which shall not be refundable (information available from the Public Procurement Authority at [www.ppoa.go.ke](http://www.ppoa.go.ke)).

### 3. Standstill Period

- a) **DEADLINE:** The Standstill Period is due to end at midnight on [*insert date*] (local time).
  - i) The Standstill Period lasts ten (14) Days after the date of transmission of this Notification of Intention to Award.
  - ii) The Standstill Period may be extended as stated in Section 4 above.

If you have any questions regarding this Notification please do not hesitate to contact us. On behalf of the Procuring Entity:

Name \_\_\_\_\_ Title and Position \_\_\_\_\_

Signature \_\_\_\_\_ Date \_\_\_\_\_

[October 2024]

**FORM NO. 2 - REQUEST FOR REVIEW**

**FORM FOR REVIEW (r.203 (1))**

**PUBLIC PROCUREMENT ADMINISTRATIVE REVIEW BOARD**

**APPLICATION NO.....OF.....20.....**

**BETWEEN**

.....**APPLICANT**

**AND**

.....**RESPONDENT (Procuring Entity)**

Request for review of the decision of the..... (Name of the Procuring Entity of .....dated the...day of .....20.....in the matter of Tender No.....of .....20..... for ..... (Tender description).

**REQUEST FOR REVIEW**

I/We.....,the above named Applicant(s), of address: Physical address.....P. O. Box No..... Tel. No.....Email ....., hereby request the Public Procurement Administrative Review Board to review the whole/part of the above mentioned decision on the following grounds , namely:

- 1.
- 2.

By this memorandum, the Applicant requests the Board for an order/orders that:

- 1.
- 2.

SIGNED ..... (Applicant) Dated on.....day of ...../...20.....

FOR OFFICIAL USE ONLY Lodged with the Secretary Public Procurement Administrative Review Board on.....day of .....20.....

**SIGNED**

**Board Secretary**

[October 2024]

**FORM NO. 3 - NOTIFICATION OF AWARD**

**Letter of Acceptance**

*[letter head paper of the*

*Procuring Entity] [date]*

**FORMAT**

To: *[name and address of the Contractor]*

This is to notify you that your Tender dated *[date]* for execution of the *[name of the Contract and identification number, as given in the SCC]* for the Accepted Contract Amount *[amount in numbers and words] [name of currency]*, as corrected and modified in accordance with the Instructions to Tenderers, is hereby accepted by our Agency.

You are requested to furnish the Performance Security within 30 days in accordance with the Conditions of Contract, using, for that purpose, one of the Performance Security Forms included in Section X, Contract Forms, of the tender document.

We attach a copy of the Contract for your

Authorized

Signature:

Name and Title

of Signatory:

Name of

Agency:

**Attachment: Contract Agreement**

[October 2024]

**FORM NO. 4 – CONTRACT AGREEMENT**

THIS AGREEMENT made the \_\_\_\_\_ day of \_\_\_\_\_, \_\_\_\_\_, between

\_\_\_\_\_ of \_\_\_\_\_ (hereinafter “the Procuring Entity”), of the one part, and \_\_\_\_\_ of \_\_\_\_\_ (herein after “the Contractor”), of the other part:

WHEREAS the Procuring Entity desires that the Works known as \_\_\_\_\_<sup>S</sup>

should be executed by the Contractor, and has accepted a Tender by the Contractor for the execution and completion of these Works and the remedying of any defects therein, The Procuring Entity and the Contractor agree as follows:

1. In this Agreement words and expressions shall have the same meanings as are respectively assigned to them in the Contract documents referred to.
2. The following documents shall be deemed to form and be read and construed as part of this Agreement. This Agreement shall prevail over all other Contract documents.
  - a) The Letter of Acceptance
  - b) The Letter of Tender
  - c) The addenda Nos \_\_\_\_\_ (if any)
  - d) The Particular Conditions
  - e) The General Conditions;
  - f) The Specification
  - g) The Drawings; and
  - h) The completed Schedules and any other documents forming part of the contract.
3. In consideration of the payments to be made by the Procuring Entity to the Contractor as specified in this Agreement, the Contractor hereby covenants with the Procuring Entity to execute the Works and to remedy defects therein in conformity in all respects with the provisions of the Contract.
4. The Procuring Entity hereby covenants to pay the Contractor in consideration of the execution and completion of the Works and the remedying of defects therein, the Contract Price or such other sum as may become payable under the provisions of the Contract at the times and in the manner prescribed by the Contract.

IN WITNESS whereof the parties hereto have caused this Agreement to be executed in accordance with the laws of Kenya on the day, month and year specified above.

Signed by \_\_\_\_\_  
\_\_\_\_\_ (for the Procuring Entity)

Signed by \_\_\_\_\_  
\_\_\_\_\_ (for the Contractor)

[October 2024]

**FORM NO. 5 - PERFORMANCE SECURITY  
– (Unconditional Demand Bank Guarantee)**

[Guarantor letterhead or SWIFT identifier code]

**Beneficiary:** \_\_\_\_\_ [insert name and Address of

Procuring Entity] **Date:** \_\_\_\_\_ [Insert date of issue]

**PERFORMANCE GUARANTEE No.:**

**Guarantor:** [Insert name and address of place of issue, unless indicated in the letterhead]

1. We have been informed that \_\_\_\_\_ (herein after called "the Applicant") has entered into Contract No. \_\_\_\_\_ dated \_\_\_\_\_ with the Beneficiary, for the execution of \_\_\_\_\_ (herein after called "the Contract").
2. Furthermore, we understand that, according to the conditions of the Contract, a performance guarantee is required.
3. At the request of the Applicant, we as Guarantor, here by irrevocably undertake to pay the Beneficiary any sum or sums not exceeding in total an amount of \_\_\_\_\_ ( ),<sup>1</sup> such sum being payable in the types and proportions of currencies in which the Contract Price is payable, upon receipt by us of the Beneficiary's complying demand supported by the Beneficiary's statement, whether in the demand itself or in a separate signed document accompanying or identifying the demand, stating that the Applicant is in breach of its obligation(s) under the Contract, without the Beneficiary needing to prove or to show grounds for your demand or the sum specified therein.
4. This guarantee shall expire, no later than the ..... Day of ..... 2...., and any demand for payment under it must be received by us at this office indicated above on or before that date.
5. The Guarantor agrees to a one-time extension of this guarantee for a period not to exceed [six months] [one year], in response to the Beneficiary's written request for such extension, such request to be presented to the Guarantor before the expiry of the guarantee."

\_\_\_\_\_  
[Name of Authorized Official, signature(s) and seals/stamps]

**Note: All italicized text (including footnotes) is for use in preparing this form and shall be deleted from the final product.**

<sup>1</sup>The Guarantor shall insert an amount representing the percentage of the Accepted Contract Amount specified in the Letter of Acceptance, less provisional sums, if any, and denominated either in the currency(cies) of the Contract or a freely convertible currency acceptable to the Beneficiary.

<sup>2</sup>Insert the date twenty-eight days after the expected completion date as described in GC Clause 11.9. The Procuring Entity should note that in the event of an extension of this date for completion of the Contract, the Procuring Entity would need to request an extension of this guarantee from the Guarantor. Such request must be in writing and must be made prior to the expiration date established in the guarantee. In preparing this guarantee, the Procuring Entity might consider adding the following text to the form, at the end of the pen ultimate paragraph: "The Guarantor agrees to a one-time extension of this guarantee for a period not to exceed [six months] [one year], in response to the Beneficiary's written request for such extension, such request to be presented to the Guarantor before the expiry of the guarantee."

[October 2024]

**FORM NO. 6 - ADVANCE PAYMENT SECURITY**

**[Demand Bank Guarantee]** [*Guarantor letterhead or SWIFT identifier code*] [*Guarantor letterhead or SWIFT identifier code*]

**Beneficiary:** \_\_\_\_\_ [*Insert name and Address of Procuring Entity*] **Date:** \_\_\_\_\_ [*Insert date of issue*]

**ADVANCE PAYMENT GUARANTEE No.:** \_\_\_\_\_ [*Insert guarantee reference number*]

**Guarantor:** [*Insert name and address of place of issue, unless indicated in the letterhead*]

1. We have been informed that \_\_\_\_\_ (herein after called "the Applicant") has entered into Contract No. \_\_\_\_\_ dated \_\_\_\_\_ with the Beneficiary, for the execution of (herein after called "the Contract").
2. Furthermore, we understand that, according to the conditions of the Contract, an advance payment in the sum \_\_\_\_\_ ( ) is to be made against an advance payment guarantee.
3. At the request of the Applicant, we as Guarantor, hereby irrevocably undertake to pay the Beneficiary any sum or sums not exceeding in total an amount of \_\_\_\_\_ ( ) upon receipt by us of the Beneficiary's complying demand supported by the Beneficiary's statement, whether in the demand itself or in a separate signed document accompanying or identifying the demand, stating either that the Applicant:
  - a) Has used the advance payment for purposes other than the costs of mobilization in respect of the Works; or
  - b) has failed to repay the advance payment in accordance with the Contract conditions, specifying the amount which the Applicant has failed to repay.
4. A demand under this guarantee may be presented as from the presentation to the Guarantor of a certificate from the Beneficiary's bank stating that the advance payment referred to above has been credited to the Applicant on its account number \_\_\_\_\_ at \_\_\_\_\_
5. The maximum amount of this guarantee shall be progressively reduced by the amount of the advance payment repaid by the Applicant as specified in copies of interim statements or payment certificates which shall be presented to us. This guarantee shall expire, at the latest, upon our receipt of a copy of the interim payment certificate indicating that ninety (90) percent of the Accepted Contract Amount, less provisional sums, has been certified for payment, or on the \_\_\_\_\_ day of \_\_\_\_\_, 2\_\_\_\_\_, whichever is earlier. Consequently, any demand for payment under this guarantee must be received by us at this office on or before that date.
6. The Guarantor agrees to a one-time extension of this guarantee for a period not to exceed [*six months*] [*one year*], in response to the Beneficiary's written request for such extension, such request to be presented to the Guarantor before the expiry of the guarantee.

[*Name of Authorized Official, signature(s) and seals/stamps*]

**Note:** All italicized text (including footnotes) is for use in preparing this form and shall be deleted from the final product.

[October 2024]

<sup>1</sup> *The Guarantor shall insert an amount representing the amount of the advance payment and denominated either in the currency(ies) of the advance payment as specified in the Contract, or in a freely convertible currency acceptable to the Procuring Entity.*

<sup>2</sup> *Insert the expected expiration date of the Time for Completion. The Procuring Entity should note that in the event of an extension of the time for completion of the Contract, the Procuring Entity would need to request an extension of this guarantee from the Guarantor. Such request must be in writing and must be made prior to the expiration date established in the guarantee. In preparing this guarantee, the Procuring Entity might consider adding the following text to the form, at the end of the penultimate paragraph: “The Guarantor agrees to a one-time extension of this guarantee for a period not to exceed [six months] [one year], in response to the Beneficiary's written request for such extension, such request to be presented to the Guarantor before the expiry of the guarantee.”*



[October 2024]

**FORM NO. 7 - RETENTION MONEY SECURITY**  
**[Demand Bank Guarantee]**

[Guarantor letterhead]

**Beneficiary:** \_\_\_\_\_ [Insert name and Address of Procuring Entity] **Date:** \_\_\_\_\_ [Insert date of issue]

**ADVANCE PAYMENT GUARANTEE No.:** \_\_\_\_\_  
[Insert guarantee reference number]

**Guarantor:** [Insert name and address of place of issue, unless indicated in the letterhead]

1. We have been informed that \_\_\_ [insert name of Contractor, which in the case of a joint venture shall be the name of the joint venture] (herein after called" the Contractor") has entered into Contract No. \_\_\_ [insert reference number of the contract] dated \_\_\_\_\_ with the Beneficiary, for the execution of \_\_\_\_\_ [insert name of contract and brief description of Works] (herein after called" the Contract").

2. Furthermore, we understand that, according to the conditions of the Contract, the Beneficiary retains moneys up to the limit set forth in the Contract ("the Retention Money"), and that when the Taking-Over Certificate has been issued under the Contract and the first half of the Retention Money has been certified for payment, and payment of [insert the second half of the Retention Money] is to be made against a Retention Money guarantee.

3. At the request of the Contractor, we, as Guarantor, hereby irrevocably undertake to pay the Beneficiary any sum or sums not exceeding in total an amount of [insert amount in figures] \_\_\_\_\_ ([insert amount in words \_\_\_\_\_])<sup>1</sup> upon receipt by us of the Beneficiary's complying demand supported by the Beneficiary's statement, whether in the demand itself or in a separate signed document accompanying or identifying the demand, stating that the Contractor is in breach of its obligation(s) under the Contract, without your needing to prove or show grounds for your demand or the sum specified therein.

4. A demand under this guarantee may be presented as from the presentation to the Guarantor of a certificate from the Beneficiary's bank stating that the second half of the Retention Money as referred to above has been credited to the Contractor on its account number \_\_\_\_\_ at \_\_\_\_\_ [insert name and address of Applicant's bank].

5. This guarantee shall expire no later than the..... Day of....., 2...<sup>2</sup>, and any demand for payment under it must be received by us at the office indicated above on or before that date.

6. The Guarantor agrees to a one-time extension of this guarantee for a period not to exceed [six months] [one year], in response to the Beneficiary's written request for such extension, such request to be presented to the Guarantor before the expiry of the guarantee. \_\_\_\_\_

\_\_\_\_\_  
[Name of Authorized Official, signature(s) and seals/stamps]

**Note: All italicized text (including foot notes) is for use in preparing this form and shall be deleted from the final product**

[October 2024]

**FORM NO. 8 - BENEFICIAL OWNERSHIP DISCLOSURE FORM**

**INSTRUCTIONS TO TENDERERS: DELETE THIS BOX ONCE YOU HAVE COMPLETED THE FORM**

*This Beneficial Ownership Disclosure Form (“Form”) is to be completed by the successful tenderer pursuant to Regulation 13 (2A) and 13 (6) of the Companies (Beneficial Ownership Information) Regulations, 2020. In case of joint venture, the tenderer must submit a separate Form for each member. The beneficial ownership information to be submitted in this Form shall be current as of the date of its submission.*

*For the purposes of this Form, a Beneficial Owner of a Tenderer is any natural person who ultimately owns or controls the legal person (tenderer) or arrangements or a natural person on whose behalf a transaction is conducted, and includes those persons who exercise ultimate effective control over a legal person (Tenderer) or arrangement.*

Tender Reference No.: \_\_\_\_\_ [insert identification no]  
 Name of the Tender Title/Description: \_\_\_\_\_ [insert name of the assignment] to:  
 \_\_\_\_\_ [insert complete name of Procuring Entity]

In response to the requirement in your notification of award dated [insert date of notification of award] to furnish additional information on beneficial ownership: \_\_\_\_\_ [select one option as applicable and delete the options that are not applicable]

I) We here by provide the following beneficial ownership information.  
**Details of beneficial ownership**

	Details of all Beneficial Owners		% of shares a person holds in the company Directly or indirectly	% of voting rights a person holds in the company	Whether a person directly or indirectly holds a right to appoint or remove a member of the board of directors of the company or an equivalent governing body of the Tenderer (Yes / No)	Whether a person directly or indirectly exercises significant influence or control over the Company (tenderer) (Yes / No)
1.	Full Name		Directly----- --- % of shares	Directly..... ....% of voting rights	1. Having the right to appoint a majority of the board of the directors or an equivalent governing body of the Tenderer: Yes ----No----  2. Is this right held directly or indirectly?:  Direct..... ...	1. Exercises significant influence or control over the Company body of the Company (tenderer)  Yes ----No----  2. Is this influence or control exercised
	National identity card number or Passport number		Indirectly----- ---- % of shares	Indirectly-----% of voting rights		
	Personal Identification Number (where applicable)					
	Nationality					
	Date of birth [dd/mm/yyyy]					
	Postal address					
	Residential address					
	Telephone number					

[Request for Proposals for Webuye Weighbridge Station and the 2073 KM Adjacent Road Network]

[October 2024]

Details of all Beneficial Owners		% of shares a person holds in the company Directly or indirectly	% of voting rights a person holds in the company	Whether a person directly or indirectly holds a right to appoint or remove a member of the board of directors of the company or an equivalent governing body of the Tenderer (Yes / No)	Whether a person directly or indirectly exercises significant influence or control over the Company (tenderer) (Yes / No)	
Email address				Indirect..... .....	directly or indirectly?	
	Occupation or profession				Direct..... .	
					Indirect..... ...	
2.	Full Name		Directly----- --- % of shares	Directly..... ...% of voting rights	1. Having the right to appoint a majority of the board of the directors or an equivalent governing body of the Tenderer: Yes ----No----  2. Is this right held directly or indirectly?:  Direct..... ...  Indirect..... .....	1. Exercises significant influence or control over the Company body of the Company (tenderer)  Yes ----No----  2. Is this influence or control exercised directly or indirectly?  Direct..... .  Indirect..... ...
	National identity card number or Passport number					
	Personal Identification Number (where applicable)		Indirectly----- ---- % of shares	Indirectly-----% of voting rights		
	Nationality(ies)					
	Date of birth [dd/mm/yyyy]					
	Postal address					
	Residential address					
	Telephone number					
	Email address					
Occupation or profession						
3.  e.t. c						

[October 2024]

II) Am fully aware that beneficial ownership information above shall be reported to the Public Procurement Regulatory Authority together with other details in relation to contract awards and shall be maintained in the Government Portal, published and made publicly available pursuant to Regulation 13(5) of the Companies (Beneficial Ownership Information) Regulations, 2020. (Notwithstanding this paragraph Personally Identifiable Information in line with the Data Protection Act shall not be published or made public). *Note that Personally Identifiable Information (PII) is defined as any information that can be used to distinguish one person from another and can be used to deanonymize previously anonymous data. This information includes National identity card number or Passport number, Personal Identification Number, Date of birth, Residential address, email address and Telephone number.*

III) In determining who meets the threshold of who a beneficial owner is, the Tenderer must consider a natural person who in relation to the company:

- (a) holds at least ten percent of the issued shares in the company either directly or indirectly;
- (b) exercises at least ten percent of the voting rights in the company either directly or indirectly;
- (c) holds a right, directly or indirectly, to appoint or remove a director of the company; or
- (d) exercises significant influence or control, directly or indirectly, over the company.

IV) What is stated to herein above is true to the best of my knowledge, information, and belief.

*Name of the Tenderer: .....\*[insert complete name of the Tenderer]\_\_\_\_\_*

*Name of the person duly authorized to sign the Tender on behalf of the Tenderer: \*\* [insert complete name of person*

*duly authorized to sign the Tender]*

*Designation of the person signing the Tender: ..... [insert complete title of the person signing the Tender] Signature of the person named above: ..... [insert signature of person whose name and capacity are shown above]*

*Date this ..... [insert date of signing] day of..... [Insert month], [insert year]*

Bidder Official Stamp

[October 2024]

## **AXLE LOAD ENFORCEMENT AND HIGHWAY UNIT - ORGANISATION CHART**

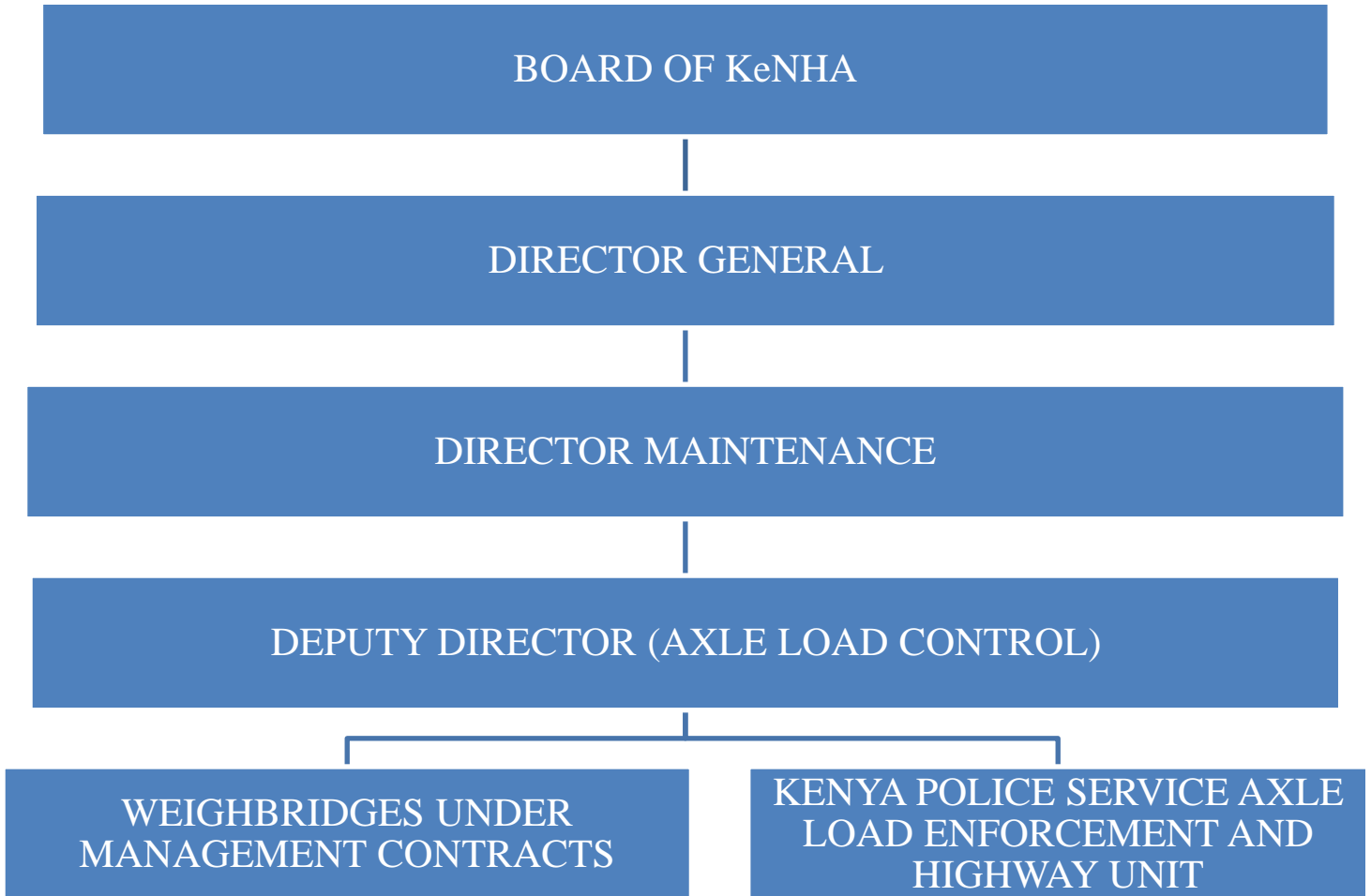

[October 2024]

**STANDARD ORGANISATION CHART FOR WEIGHBRIDGE STATION**

*The Contractor to insert his proposed site organization chart*